

Type RC3D Load Cell

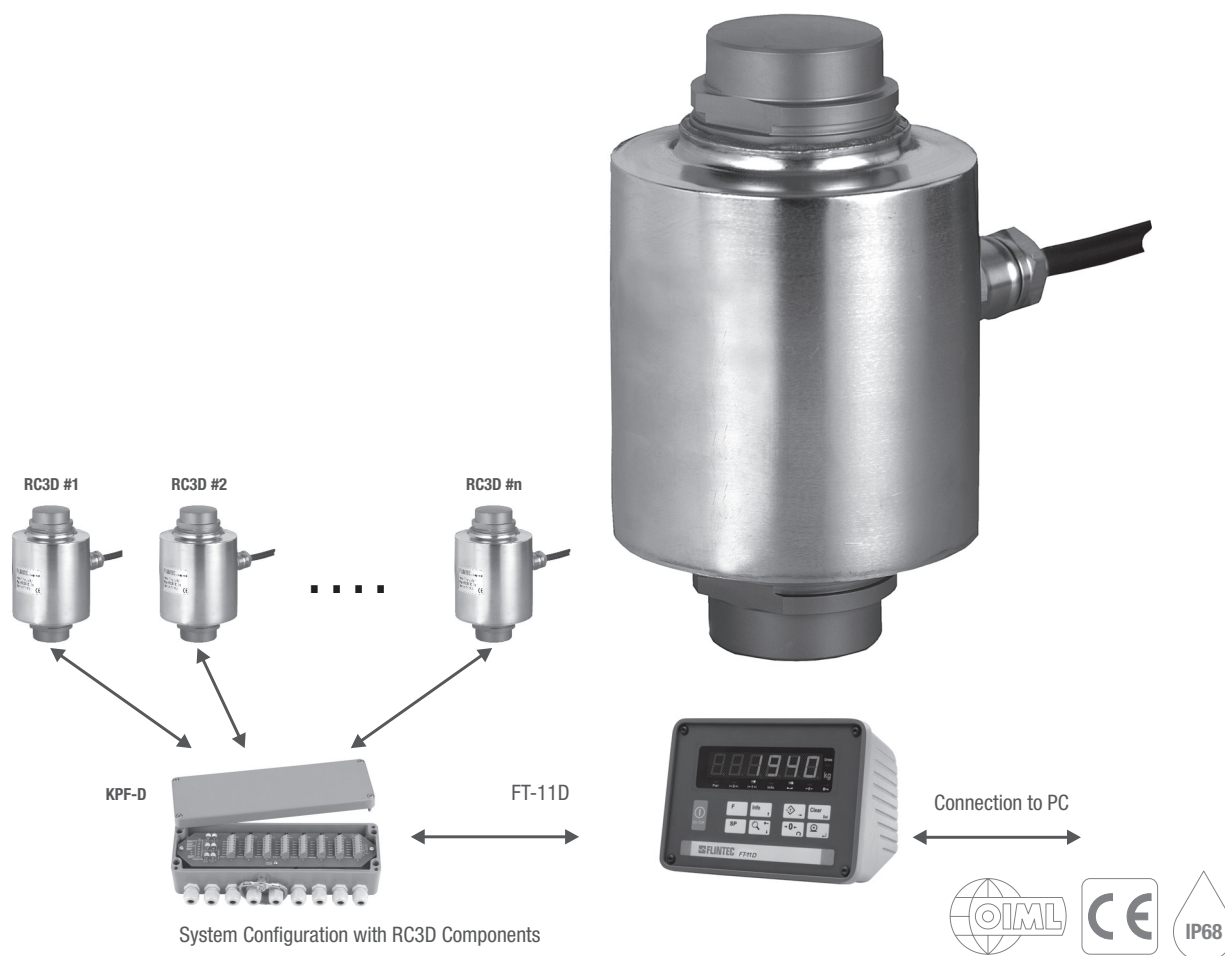

Product Description

The type RC3D is the digital version of the successful RC3 rocker column load cell. An integrated state of the art microprocessor system within the load cell improves system accuracy and load cell handling. The digital output enables the user to communicate with each load cell independently from others.

Application

- Weighbridges, hoppers, tanks and silos

Key Features

- Capacities of 30, 40 and 50 t
- Stainless steel construction
- Environmental Protection IP68 with complete hermetic sealing
- Self restoring design
- Digital load cell with built-in microcontroller and A/D conversion
- Easy communication (RS485) and fast system setup
- Improved handling of corner adjustment, system calibration, fault finding and load cell replacement

Approvals

- OIML approval to C1 (Y = 5 000), C3 and C4 (Y = 15 000)

Packed Weight

- | | | | |
|----------------|-----|-----|-----|
| ■ Capacity (t) | 30 | 40 | 50 |
| ■ Weight (kg) | 3.3 | 3.6 | 4.5 |

Available Accessories

- Compatible range of applications hardware
- Compatible range of electronics

RC3D Specifications

	(E_{max})	t	30 / 40 / 50			
			(GP)	C1	C3	C4
Accuracy class according to OIML R60			(GP)	C1	C3	C4
Maximum number of verification intervals	(n_{LC})		n.a.	1 000	3 000	4 000
Minimum load cell verification interval	(v_{min})		n.a.	$E_{max} / 5 000$	$E_{max} / 15 000$	
Temperature effect on minimum dead load output	(TC_0)	$\% \cdot RO / 10^{\circ}C$	$\leq \pm 0.0400$	$\leq \pm 0.0280$	$\leq \pm 0.0093$	
Temperature effect on sensitivity	(TC_{RO})	$\% \cdot RO / 10^{\circ}C$	$\leq \pm 0.0200$	$\leq \pm 0.0160$	$\leq \pm 0.0100$	$\leq \pm 0.0080$
Combined error		$\% \cdot RO$	$\leq \pm 0.0500$	$\leq \pm 0.0300$	$\leq \pm 0.0200$	$\leq \pm 0.0180$
Non-linearity		$\% \cdot RO$	$\leq \pm 0.0400$	$\leq \pm 0.0300$	$\leq \pm 0.0166$	$\leq \pm 0.0125$
Hysteresis		$\% \cdot RO$	$\leq \pm 0.0400$	$\leq \pm 0.0300$	$\leq \pm 0.0166$	$\leq \pm 0.0125$
Creep error (30 minutes) / DR		$\% \cdot RO$	$\leq \pm 0.0600$	$\leq \pm 0.0490$	$\leq \pm 0.0166$	$\leq \pm 0.0125$
Rated Output	(RO)	counts	200 000			
Internal resolution		counts	550 000			
Excitation voltage		V	9...12			
Current consumption		mA	40			
Converter type			Sigma-Delta ratiometric			
Conversion rate			3 to 70 Hertz (selectable)			
Digital filter			FIR automatically adjusted to conversion rate plus Rolling Average (1, 2, 4, 8, 16, 32 samples) post filtering			
Asynchrone interface			RS485A half duplex, multidrop with network address, 2400...38400 baud Baudrate, data bits, parity and data output are programmable			
Number of bus addresses			32			
Safe load limit	(E_{lim})	$\% \cdot E_{max}$	200			
Ultimate load		$\% \cdot E_{max}$	300			
Compensated temperature range		$^{\circ}C$	-10...+40			
Operating temperature range		$^{\circ}C$	-40...+80			
Load cell material			stainless steel 17-4 PH (1.4548)			
Sealing			complete hermetic sealing; cable entry sealed by glass to metal header			
Protection according DIN 40.050			IP68			

The limits for Non-Linearity, Hysteresis, and TC_{RO} are typical values.
The sum of Non-linearity, Hysteresis and TC_{RO} meets the requirements according to OIML R60 with $p_{LC}=0.7$.

Dimensions (in mm)

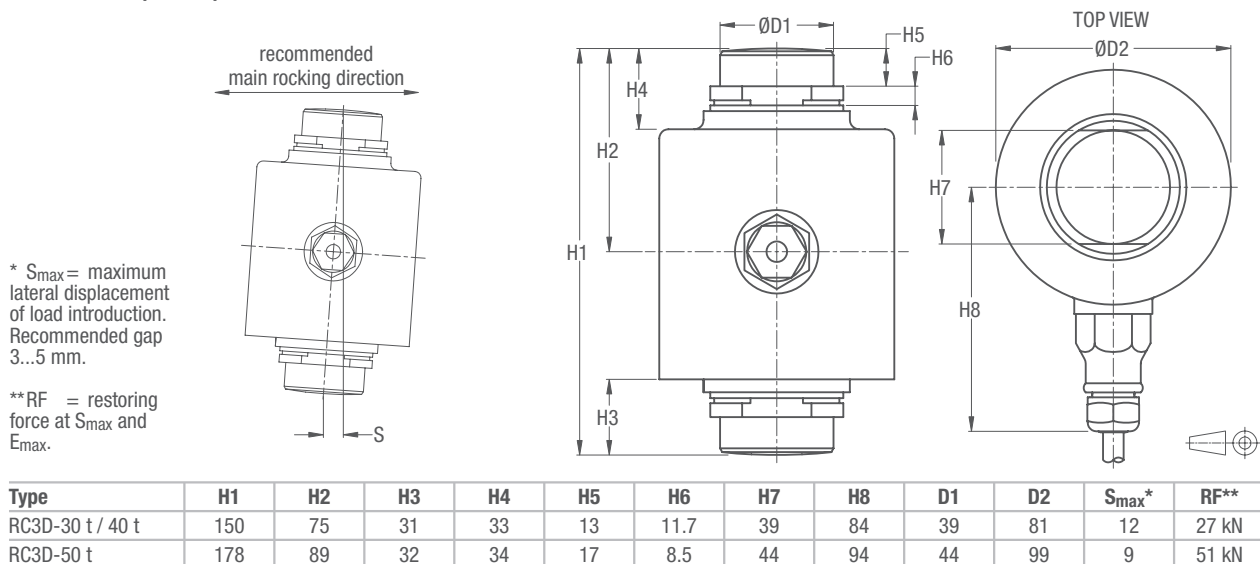

Wiring

- The load cell is provided with a 3x twisted pair cable (AWG 24) and shield according DIN 47 100
- Cable length: 18 m
- Cable diameter: 7.4 mm
- The shield is connected to the load cell body

