

TRADE
Software module for the legal-for-trade display and storage of scale data with digital transducer electronics AD10x.

Version: 1.1
As at: 01.01.2002

This manual contains:

- 1. Chapter 1 – Chapter 13: TRADE operating instructions**
- 2. From Chapter 14: installation and service instructions**
- 3. Chapter 14.8: quick installation of TRADE**

HBM TRADE offers you:

- Legal-for-trade display/storage** of scale data in the PC system with Windows (32 bits) – independently of your application
- Interfacing **arbitrary** applications or standard programs (e.g. MS-WORD/EXCEL) via **DDE interface** or **DLL entry**
- Real 32-bit application** – executable under Windows 95/98/NT/2000
- Connection of up to 8 scales with up to 16 digital load cells of the type AD10x each

1 Content

1	CONTENT	2
2	INTRODUCTION	5
3	DUTIES OF THE OPERATOR	6
4	MAIN WINDOW OF TRADE	6
4.1	TITLE AND SCALE NAME PLATE (1)	6
4.2	MENU (2)	7
4.3	TOOL DISPLAY (3)	7
4.4	WEIGHT DISPLAY OR WEIGHING LIST (4)	8
4.4.1	<i>Weight display symbols</i>	8
4.5	STATUS ROW (5)	9
5	DISPLAY DATA-STORAGE-DEVICE (DSD) FILES	10
5.1	FUNCTIONS (1)	10
5.2	TABLE WITH LEGAL DATA (2)	10
5.3	STATUS ROW (3)	11
6	COMMAND PANEL	12
6.1	FUNCTIONS (1)	12
6.2	DATA FIELD (2)	13
6.3	STATUS ROW (3)	13
7	OPTION – FONTS/COLOUR	14
8	SIMULATION	14
8.1	FUNCTIONS (1)	14
8.2	STATUS ROW (2)	15
9	(?) - CHECK	16
10	MAINTENANCE DISPLAY	17
11	RESTORING DATA AFER PC-REPLACEMENT	17
12	SETUP UNDER OPERATOR CONTROL	18
12.1	FUNCTIONS OF THE FOOT ROW (1)	18
12.1.1	<i>EDIT Context menu for the operator by means of right mouse button (2)</i>	19
12.2	GENERAL REGISTER CARD (3)	19
12.2.1	<i>DSD-File data input</i>	19
12.2.2	<i>Display data input</i>	19
12.2.3	<i>Print Mode data input</i>	20
12.2.4	<i>Passwords data input</i>	20
12.3	SINGLE SCALE REGISTER CARD (4)	20
12.4	NAME/FUNCTION REGISTER CARD (5)	21
12.4.1	<i>Scale Information data input</i>	21
12.4.2	<i>Scan data input</i>	21
12.4.3	<i>Load Cell Electronic data input</i>	21
12.4.4	<i>Function data input</i>	21
13	ERROR MESSAGES AND REMEDIAL ACTION	22
14	INSTALLATION OF SCALES WITH TRADE	23
14.1	GENERAL COMMENTS ON COMMISSIONING	23
14.2	STORE CHANGES FINALLY INTO THE LOAD CELLS	23

14.3	SERIENNUMMERN DER AUFNEHMER	23
14.4	PARALLEL CONNECTION OF THE LOAD CELLS	24
14.5	SEALING THE SCALE	24
14.6	CONVERTER CONNECTION	27
14.7	POWER SUPPLY OF THE LOAD CELLS	27
14.8	FIRST STEPS WITH TRADE	28
14.9	POSSIBLE PROBLEMS AT THE INSTALLATION	34
15	OPTIONS - PARAMETER.....	35
15.1	FUNCTIONS OF THE FOOT ROW (1).....	36
15.1.1	<i>EDIT Context menu by means of right mouse button (2)</i>	36
15.2	GENERAL REGISTER CARD (3)	37
15.2.1	<i>Company data input</i>	37
15.2.2	<i>DSD-File data input</i>	38
15.2.3	<i>Display data input</i>	38
15.2.4	<i>Print Mode data input</i>	38
15.2.5	<i>Passwords data input</i>	38
15.3	SINGLE SCALE REGISTER CARD (4).....	39
15.4	NAME/FUNCTION REGISTER CARD (5).....	39
15.4.1	<i>Scale Information data input</i>	39
15.4.2	<i>Scan data input</i>	40
15.4.3	<i>Load Cell Electronic data input</i>	40
15.4.4	<i>Function data input</i>	40
15.5	NAME PLATE REGISTER CARD (6).....	41
15.5.1	<i>Name Plate data input</i>	41
15.5.2	<i>Weighing Range data input</i>	41
15.6	PARAMETER/LOAD CELL REGISTER CARD (7)	42
15.6.1	<i>Scale Application data input</i>	42
15.6.2	<i>Location data input</i>	43
15.6.3	<i>Stable Settings data input</i>	43
15.6.4	<i>Zero Settings data input</i>	43
15.7	STATUS CARD (8).....	44
16	SETUP LOAD CELLS	45
16.1	GENERAL	45
16.2	COMMUNICATION WINDOW(1).....	46
16.2.1	<i>Interface parameters</i>	46
16.2.2	<i>Setting the interface</i>	46
16.2.3	<i>Scan – Determining the connected load cells</i>	46
16.2.4	<i>Set – Determining the addresses</i>	46
16.2.5	<i>Unknown serial numbers</i>	47
16.3	LOAD CELL PARAMETER WINDOW (2)	47
16.4	LOG WINDOW (3)	48
16.5	FOOTER (4)	48
16.6	CALIBRATION WINDOW (5)	48
16.6.1	<i>Zero Adjustment</i>	48
16.6.2	<i>Calculated Adjustment w/o Weights</i>	48
16.6.3	<i>Corner Adjustment</i>	48
16.6.4	<i>Calibration</i>	49
17	TRADE ON THE PC.....	50
17.1	INSTALLATION OF TRADE.....	50
17.2	LICENSE CONDITIONS	50
17.3	DATA BACKUP	50
17.4	RESTORATION OF DATA AFTER PC REPLACEMENT	50
18	MULTIPLE SESSIONS	51
19	INTERFACE TO NOT LEGAL APPLICATION.....	51
19.1	THE INTERFACES.....	51
19.1.1	<i>Software Interface DDE</i>	51
19.1.2	<i>Software Interface DLL</i>	51

19.1.3	DDE vs. DLL.....	51
19.2	DDE INTERFACE.....	52
19.2.1	General.....	52
19.2.2	Command Structure.....	52
19.2.3	Commands.....	52
19.3	DLL INTERFACE.....	53
20	CHANGE OF LOAD CELLS.....	54
21	MULTIPLE SCALE SYSTEMS.....	55
21.1	SEVERAL SCALES WITH ONE SESSION AT A COM PORT.....	55
21.2	SEVERAL SCALES WITH ONE SESSION AT DIFFERENT COM PORTS.....	55
21.3	SEVERAL SCALES WITH SEVERAL SESSIONS AT DIFFERENT COM PORTS.....	55
22	PARAMETERS/FILES.....	56
22.1	GENERAL PARAMETERS (TRADE_G.WPD).....	56
22.2	COMMUNICATION PARAMETERS (TRADE_K.WPD).....	56
22.3	LEGAL-FOR-TRADE PARAMETERS – CHECK NUMBERS.....	56
22.4	NOT LEGAL-FOR-TRADE PARAMETERS/PER SCALE (TRADE_W.WPD).....	57
22.5	LEGAL-FOR-TRADE PARAMETERS/PER SCALE (TRADE_E.WPD).....	57
22.6	LEGAL-FOR-TRADE PARAMETERS/PER LOAD CELL (STORAGE IN AD/10x).....	58
23	TRADE MARKS.....	58
24	INDEX.....	59

2 Introduction

This manual contains:

1. Chapter 1 – Chapter 13 for daily use of TRADE
2. As from Chapter 14 for installation and service
3. Chapter 14.8 for quick installation of TRADE

The **HBM TRADE** program is a legal-for trade weighing software, which allows to operate one or multiple approved scales on a standard PC using HBM digital load cells. On the screen a window is shown which provides all relevant information and functions of a scale.

As a rule **TRADE** is not installed alone, but an additional application software provides functions as logistics, invoicing etc. and need not to fulfil any legal for trade requirements.

HBM TRADE provides the following features:

General

- ◆ Display of weighing data (substitutes indicator)
- ◆ Approved storage of weighing data on hard disk (substitutes DSD-hardware)
- ◆ PC outside of the approved chain! PC change uncritical
- ◆ Up to 16 C16i or AED9101x on one COM-Port

Scale functions

- ◆ Basic functions Tare, Zero, Gross/Net, 10x-Resolution
- ◆ Zero tracking, stable indication, zero indication
- ◆ Filter setup
- ◆ Operates up to 8 scales with 16 load cells each
- ◆ Multiple-range/Multi-interval support

Diagnostic functions

- ◆ Password protection
- ◆ Protocol about scale history
- ◆ Report on load cell overload events
- ◆ Online manipulation check

Installation functions

- ◆ Automatic scan of connected load cells
- ◆ Digital corner adjustment
- ◆ Calibration w/o weights
- ◆ Change of load cells supported

Software-Interfaces

- ◆ DDE- and DLL-Interface to non approved applications

Supported languages

English, French, Spanish, Italian, German (further on request)

3 Duties of the Operator

The user of **HBM TRADE**[®] is according to the Weights and Measures law obliged to observe the following points:

- Daily check of the displayed test mark (Section9) with the test numbers on the sealing plate
- He is solely responsible for sufficient storage capacity (1 kbyte per weighing result) and for the presence of the stored weighing result
- Continuously output weighing results without previous storage and without identification may be used only for not legal-for-trade applications (dosing, controlling, etc.). Because of the lack of identification, passing on for legal-for-trade applications is not permitted
- The business documents, which are produced by additional equipment exempted from the legal-for-trade requirement according to the preliminary remarks of Appendix I of the Directive 90/384/EECG or §7b (3) 2 of the Weights and Measures Code, must contain the following information:
 - an identification for each weighing result
 - for use in Germany in addition a note that the weighing results can be compared or checked based on the identification with the weighing results stored legal-for-trade.

4 Main Window of TRADE



Figure 1 - Main window of TRADE

Note: The tool display (3) can be switched off. You should switch it on when using this Manual.

The display consists of the following components

4.1 Title and Scale Name Plate (1)



- Scale number

- Scale name
- Min/max weight/scale division
- Standard Windows icons for changing the window view

4.2 Menu (2)

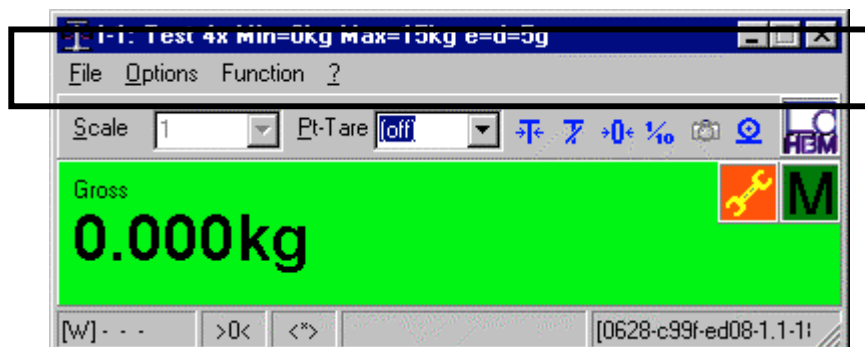

- File: Display DSD-Files
- File: Command Mode (see chapter 6)
- File: Setup Printer
- File: End of Program
- Options: Parameter
 - Operator – Access for the system operator. Can be protected by password. Relevant changes for scale approval are not possible.
 - Service – Access to all parameters. Can be protected by password.
 - Simulation – Only available if simulation scales are active. See chapter 8)
- Options: Fonts/Colour(see chapter 7)
- Options: Scale Display or Weighing List
- Options: Tool Display
- Function: All Functions of the Tool Display
- ?: Check – Display of the check sums(see chapter 9)

4.3 Tool Display (3)

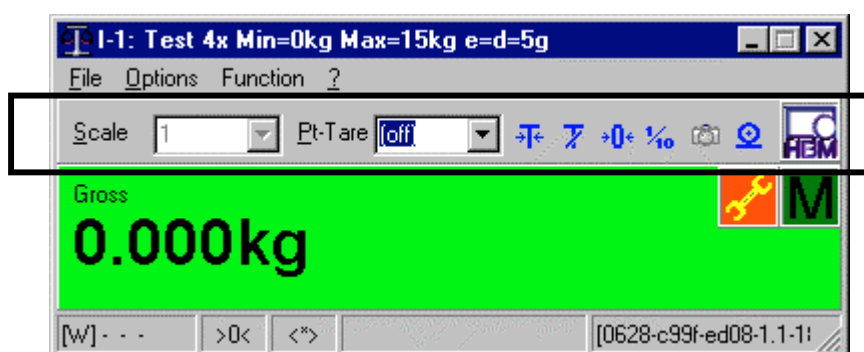

- Scale selection (F4)
- Selection/deselection of tare and manual tare (F5)
- Tare on (F6) – Legal for trade scales do not accept taring at gross zero and at negative gross values
- Tare off (F7)
- Zero setting (F8) – Legal scales have limitations in the zero setting range e.g. +/- 2%. Trail to zero outside that range causes a "Zero out of Range" error. Restart TRADE because the automatic zeroing at start up provides a much wider range.

- 10-times resolution for 5 seconds (F9) – During that time the system is not approved
- Logging function for 'freezing' the last 100 data records. A display which essentially corresponds to the weighing list appears. (F11)
- Weighing and storing (F12) – One weighing record to be stored in the DSD-file

Notes:

- The entries in the function bar are available only if the connected scale also supports the relevant function or these are activated in the parameter settings.
- These functions are also available through the menu bar (functions) as well as through the function keys.

4.4 Weight display or Weighing List (4)



Gross or net/tare with labelling or weighing list as shown in Figure 2. For this purpose use the function **Main Menu → Option → Scale Display**.

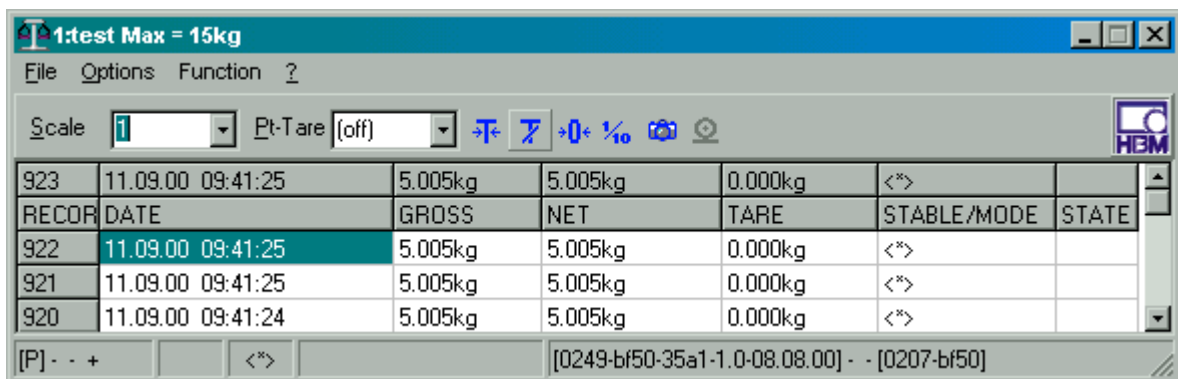

Figure 2 – Main window with weighing list instead of scale display

- Date/time
- Weight
- Rest and zero position
- Status (e.g. overload)

This type of display is selected if one wants to observe the course of weight values.

4.4.1 Weight display symbols



The green „M“ is the symbol for legal for trade scales. Industrial mode scales do not show this symbol.



The red struck-out "M" indicates a fault in the scales. This also applies to scales in industrial mode. Trade was unable to initialise the scales correctly. The following causes are possible:

- ◆ There is no communication established with the transducers. In this case there would then be no weight display either. Check the voltage supply to the load cells, connections, your PC etc. You can use the program CHECKCOM to check communication with the transducers.
- ◆ There is a weight display, but a red M is shown. Trade has read incorrect parameters. Initially, select the scales again (F4). If this should not be successful, re-start TRADE.
- ◆ Programs or calibration parameters have been changed. Please contact the manufacturer of your scales. This display indication will be shown until the parameters are next stored (re-calibration!).



If you should see the maintenance symbol you can obtain further information by clicking on this symbol. See also Chap. 10

4.5 Status Row (5)



- [W+++] Communication status (AD-electronics, scale, display). If all three crosses are flashing your scale is working.
- Zero indication (>O< = center of zero within $0 \pm 1/4d$, >o< = zero tracking is working)
- <*> = Scale is stable
- Scale error/status (range indication, underload etc.)
- Test identifier (=all checksums)

Note: It can be determined by means of the check sums whether the program has been loaded correctly (comparison with sealing plate). This check should be performed at least 1x daily at program start.

The following additional information is displayed for service purposes by double-clicking on the status row:

- Communication status (in data records/seconds)
- Interface status (number of repetitions for Send/Receiving/Timeout (S/R/T))

5 Display Data-Storage-Device (DSD) Files

Main Menu → File → Display DSD Files

Weighing data is stored in that area legal for trade. To refer to DSD-data e.g. in an invoice the signature has to be given together with it.

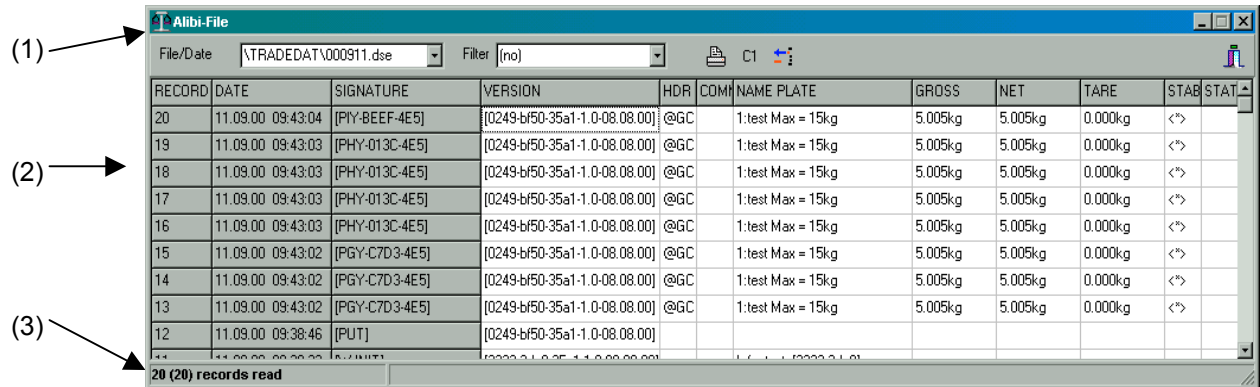

Figure 3 - Display Data-Storage-Device (DSD) Files

A window consisting of the following components appears:

5.1 Functions (1)

- **File/Date.** A standard file selection in which another DSD file file can be selected appears by double-clicking on this icon. Each day a new calibration file is created. In order to locate this file more easily across an extended period of time, it is designated as follows: YYMMDD.dse
- **Filter.** The display can be restricted by entering a filter expression. The entry can be made with so-called wildcards (jokers).
Example: Entry *4711 displays all data records which contain the expression 4711 in an arbitrary field. For instance, a data record with article (user key) 4711 can be found.
- **Printer icon.** Printout of the screen contents.
- **C1.** Switching over between one and three fixed columns.
- **Update icon.** Deletion of all DSD files which are older than 3 (according to setting also more) months.

5.2 Table with legal data (2)

Each table line corresponds to an entry in the DSD file. Since the DSD file has very many fields, which are partially filled with long expressions, only a part can always be displayed. The column width can be changed by clicking and dragging on the lines separating column titles. The detail can be shifted as customary with the horizontal scroll bar.

The columns correspond to the fields of the DSD file described in the command panel (see section 6).

The following pseudo signatures are also entered:

[CHECK]	Is always entered in the DSD file if a check of the checksum is made (program start).
[PUT]	Is always entered if the legal-for-trade parameters have been changed.
[W-INIT]	Is always entered if an error occurred on initializing a connected scale.
[W-CHECK]	Is always entered if an error occurred in the running check of the connected load cells.

If one of these signatures is entered, you receive further information from the *Version* and *Name Plate* columns.

5.3 Status Row (3)

The number of the data records is displayed in the status row. Furthermore it is shown how many data records the current filter criterion has filtered out.

6 Command Panel

Main Menu → File → Command Panel

The command panel allows you to communicate with TRADE via the software interface. The command panel can be used to carry out weighing tasks and to record and/or print the same. If you also store the weighing in the calibration file, calibrated weighing certificates (in a fixed format) can be printed. However, this function is usually taken over by a logistics software.

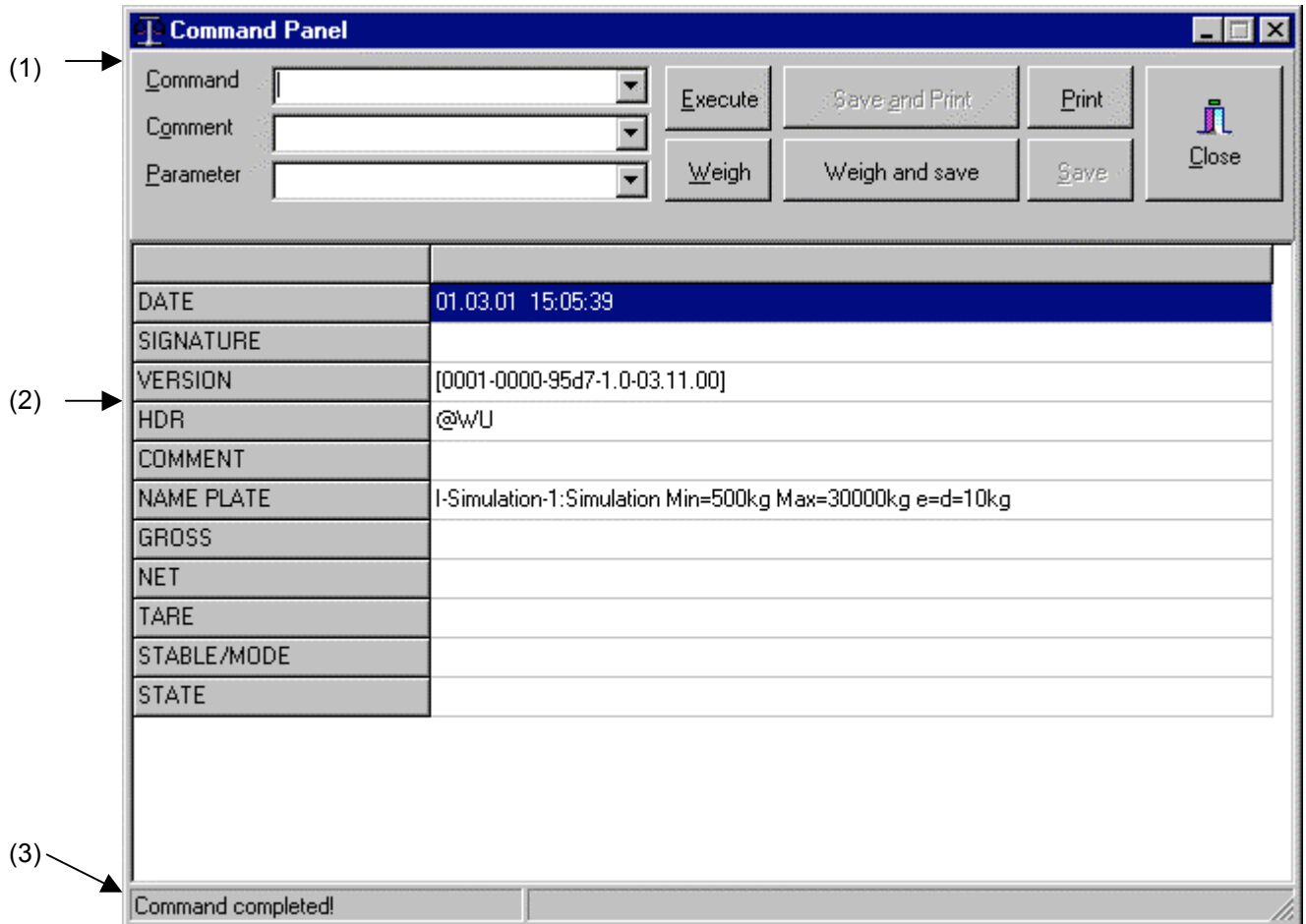

Figure 4 – TRADE Command Panel

A window consisting of the following components appears:

6.1 Functions (1)

To be able to send the command to **HBM TRADE**, one should firstly understand the structure of the commands. Each command to **HBM TRADE** consists of 3 fields:

- **Command.** The commands and their associated parameters are described in detail in the 'DDE interface' section. Commands may stand in inverted commas.
- **Comment.** This parameter is entered as user key 1:1 in the DSD file. It serves for the fast location of data records and for the plausibility check.
- **Parameter.** Some commands require parameters (e.g. manual tare value). This is entered here.

Note: The most important and last performed entries in each case can be called up by clicking on the arrow next to the entry line.

Example 1: Weight at rest see above

Example 2: Manual tare 1.23 kg Command: @TH Parameter: 1.23

After you have entered the command and possibly comment and parameters, activate the 'Execute' button. The command is processed by **HBM TRADE** and the result displayed in the '**DATE**' to '**STATE**' fields. These fields correspond to the individual columns in the display of the DSD file.

Additionally, frequently used functions can also be reached via buttons:

Weighing: corresponds to the command @GR

Storing and printing: corresponds to the command @YC;23 + printout on current printer

Weighing and storing: corresponds to the command @GC

Printing: printout on current printer

Storing: corresponds to the command @YC;23

If a weight set was stored in the calibration file, then the printout complies with the requirements of the law on legal-for-trade calibration, otherwise TRADE shows in the status line that this printout cannot be calibrated.

6.2 Data field (2)

- **DATE.** States the date/time of weighing.
- **SIGNATURE.** The signature is the actual key of the DSD file. It consists of a combination of date, time and checksum over the data record. The signature must be printed/processed in the not legal-for-trade application always together with the weight values. The signature can also be displayed encoded according to setting in the parameters, so that date/time are not detectable.
- **VERSION.** States the audit trail counter, checksums and program version level.
- **HDR.** Reproduces the 'Command' field
- **COMMENT.** Reproduces the 'Comment' field
- **NAME PLATE.** Reproduces the name plate of the relevant scale (title line). In this field, the command @AD (individual measured values from the transducers) returns the data.
- **GROSS/NET/TARE/STABLE MODE/STATE.** Reproduces the weight data and their status.

6.3 Status row (3)

The status of the command is displayed here (command completed/entered in DSD file etc.)

7 Option – Fonts/Colour

Main Menu → Option → Fonts/Colours → Area

You have the possibility of setting the font or the background colour in the following display functions:

- Weight display
- Protocol = Weighing list
- DSD file
- Command Panel
- Display colour

A selection dialog in which you can select the font, size, colour and the background colour appears in each case. The data are saved so that they are available again at the next program start.

Note: Adapt the width and height of the fields in the tables by 'clicking and dragging' on the line between the greyed columns or lines.

8 Simulation

Main Menu → Option → Parameter → Simulation

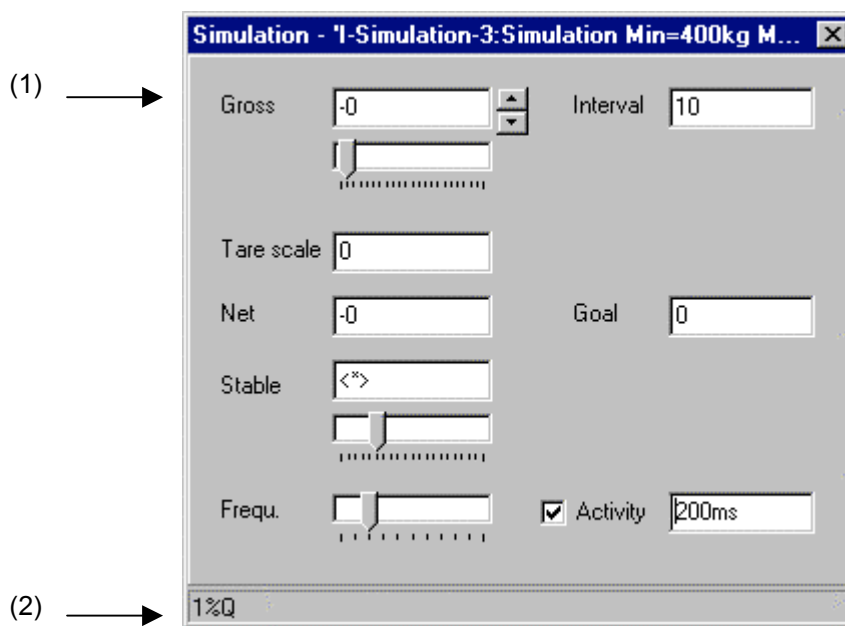

Figure 5 - Simulation of weight values

Simulation is a useful aid if for instance for test purposes a real scale is not available. A typical scale with various physical properties (e.g. unstable) is simulated. The scale simulation takes place in its own window, therefore it can be activated simultaneously to the other functions.

In this operating mode the **SIMULATION** note is displayed flashing in the status row!

Note: Parameters which directly concern the scale function (e.g. zero, rest, filter etc.) are not taken into account by the simulation.

8.1 Functions (1)

- **Gross.** The gross weight is displayed, entered or increased or decreased here. The weight can also be changed with the slide control under the field. The tare is switched off by double-clicking on this field.
- **Interval.** The step width for gross increase or decrease is set here.
- **Tare.** A possible existing tare is displayed or entered here. The current weight is set as tare by double-clicking on this field.
- **Net.** The current net weight is displayed here. The current weight is set as tare by double-clicking on this field.
- **Target.** If a value is entered here, the net weight is increased or decreased until the entered target weight is reached. In this case the weight per cycle is changed by the entered step width.
- **Stable.** Shows the current stable status. The slide control sets how stable or unstable the simulated scale appears.
- **Frequ.** Here how frequently the simulation recalculates the weight value is set. This value must be set in any event 'faster' than the weight display, since otherwise scale errors are displayed.
- **Activity.** The activity of the simulation can be switched on or off with this. If switched off, a scale error is displayed in the weight display.

Notes:

- Please note that under Windows entries are ended by means of the TAB key.
- The simulation must be selected in the legal-for-trade range of the parameters i.e. physical scales cannot be switched to simulation.

8.2 Status row (2)

The status row displays the received or transmitted data record.

9 (?) - Check

Main Menu → ? → Check



Figure 6 – Start window of TRADE

Display of the start window. The information about the manufacturer as well as the copyright are displayed in this window. Furthermore data on the customer licence can be found here. The lower part shows the sealing plate information relevant only for legal for trade scales. The operator shall check once a day if these numbers fit to the physical sealing plate. If they do not match the scales has to be re-stamped. The following are displayed in the bottom line

- the audit trail counter
- the checksums of program and parameters (= check code)
- the program version

If only '????' appears instead of the audit trail counter, programs or parameters have been changed. Possible reasons are:

- ◆ No communication with the load cells possible. No weight display. Check the power supply of the load cells, the cables etc.
- ◆ The weight display is operating, but the red M is shown. Trade read wrong parameters. Re-select the scale first. If not succesfull restart TRADE.
- ◆ Program or Parameters have been changed. Please contact Service. This display remains up to the next storage of the parameters.

Note: The display can vary in the upper area (logo/text) according to sales organization and country.

10 Maintenance Display



The maintenance display serves to remind you in time so that you do not miss any important scheduled maintenance dates. Service can enter a date in TRADE at which a scheduled maintenance must be carried out.

The maintenance symbol will appear from 3 weeks prior to this scheduled date. Click on the symbol to obtain further information as shown in Figure 7 – **Maintenance message** . In addition, this message is displayed once a day at 6.00 hrs.

From a week prior to this scheduled date, TRADE will remind you every 5 minutes with the a/m message to carry out the maintenance.

The maintenance display can be deactivated only by entering a code. The code can be obtained from the manufacturer of your scales.

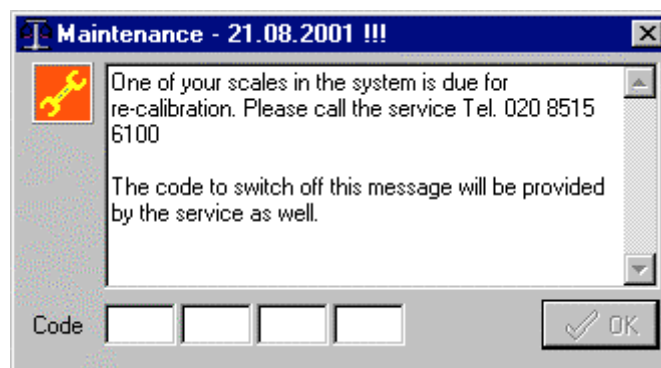

Figure 7 – Maintenance message

11 Restoring Data after PC-Replacement

TRADE offers the possibility of restoring the stored data, e.g. after the PC replacement of a defective PC if these have been backed up according to Section 17.3. Nevertheless changes which have been made in the meantime cannot be undone again by this. For restoring the data please proceed as follows:

- Select Option -> Parameter -> Service or Operator
- Click with the right mouse button on the context menu Figure 29, Item (2)
- Select "Restore"
- Enter the source directory
- The files are copied
- You must then start **TRADE** anew

Observe that restoration of data overwrite previous data !

12 Setup under Operator control

Main menu → Option → Parameter → Operator

Not all settings that are possible here are subject to a legal-for-trade calibration duty. However, you should still be careful when changing the settings. If you are uncertain, it is recommended to consult first with the manufacturer of your scales or your PC specialist. Access can be protected by means of a password.

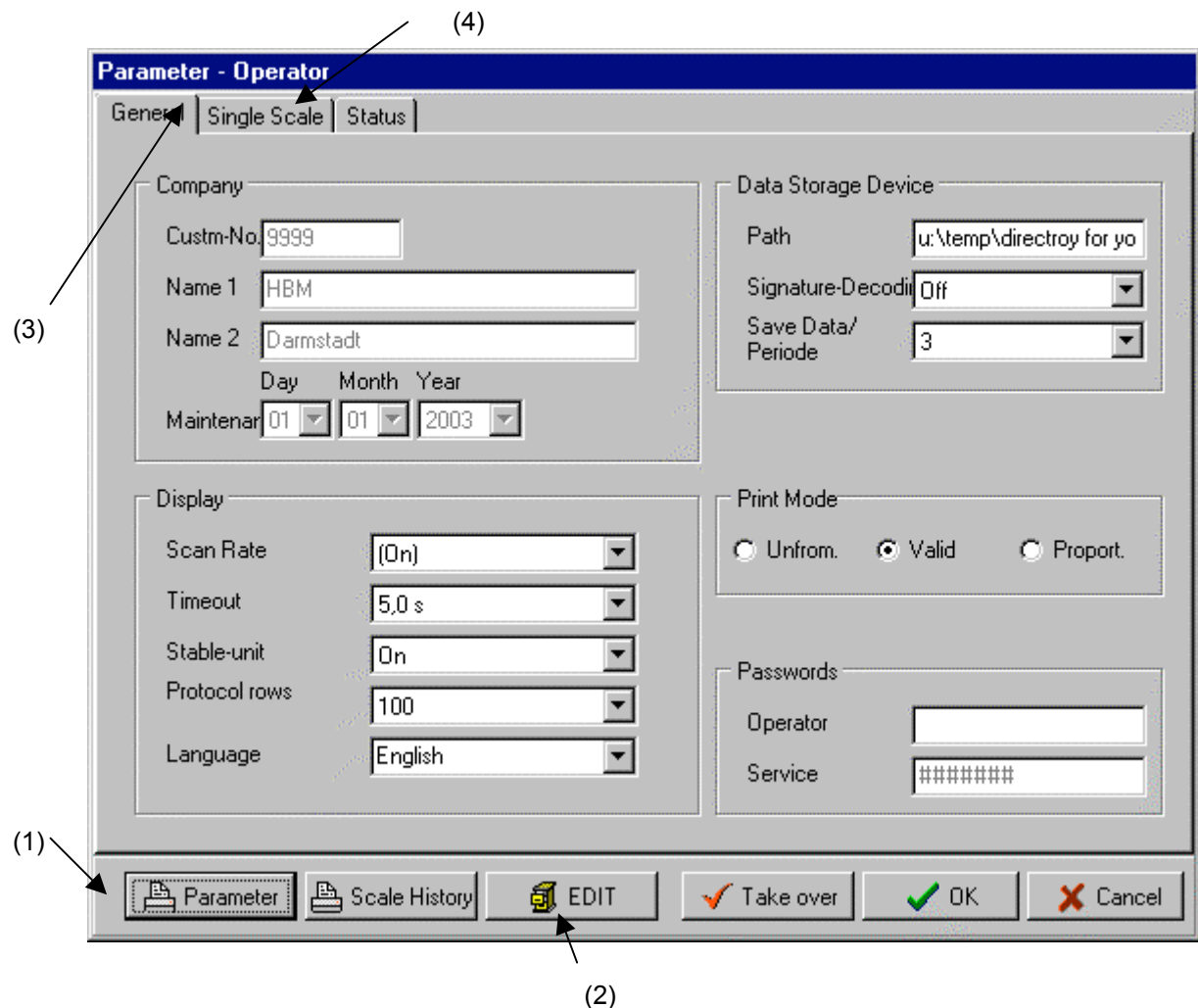

Figure 8 – Setup parameters “General” for all scales

12.1 Functions of the foot row (1)

- **'Parameter' button.** After this button is activated, the complete settings (legal for trade and not legal for trade) of all existing scales are displayed and optionally printed. Data is copied to the clipboard for further use e.g. email etc.
- **'Scale History' button.** After this button is activated, the scale history is displayed and optionally printed. Data is copied to the clipboard for further use e.g. email etc.
- **'Take Over' button.** As for OK, but the window is not exited. The scale is nevertheless set to the changed values, so that these can be checked.
- **'OK' button.** The changed data are saved. If changes have been made in the legal-for-trade area, a corresponding note appears.
- **'Cancel' button.** All previously performed changes are rejected after a prompt.

12.1.1 EDIT Context menu for the operator by means of right mouse button (2)

A context menu with further functions appears after the right mouse button is pressed over the foot row:

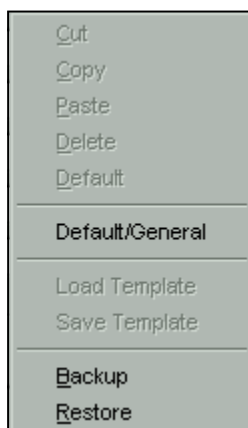

Figure 9 – Context menu

TRADE offers the option to restore the stored data, e.g. following the replacement of a defective PC, if these were backed up first. However, any changes carried out in the meantime cannot be reversed in this way. Warning! Retrieving the data will irreversibly overwrite your previous data.

- **Backup.** All files of the \TRADE directory are copied onto a required data medium.
- **Restore.** All files of the \TRADE directory are loaded back from a required data medium. In this case the current settings are deleted irrevocably!

12.2 General register card (3)

Settings for the total system possibly consisting of several scales are made here. If several sessions of TRADE are active, only those parameters of the scales can be changed, by means of which you carry out service access. However, this also allows maintenance work to be carried out on one set of scales, and the other scales to be operated normally. In this case, the general parameters are not to be altered. For this purpose only one session may be active.

12.2.1 DSD-File data input

- **Path.** Reproduces the directory for the DSD file.
- **Signature.** States how the signature is displayed, transferred and saved:
 - Off (Date legible):** Date - checksum - time - e.g. 120197-ABCD-235523
 - On (Hex-coded):** D/U1 - checksum - D/U2- e.g. XZ9-ABCD-O1PDate and time are scrambled bit-wise so that the date cannot be derived from the data record. This is expedient if date/time of the weighing should be hidden (e.g. on a delivery note).
- **Save Data/Period.** States how long calibration data should be saved (minimum value is 3 months).

12.2.2 Display data input

- **Scan Rate.** States how frequently the weight display should be updated. (*On*) means that the display is updated for each new data record.
- **Timeout.** States after which time the weight display is switched off if no further scale data are present (e.g. because the connected load cells do not respond).
- **Stable/Unit.** States whether the unit (e.g. *kg*) should be masked out in the case of scale unstable.

- **Protocol rows.** States how many rows in the weighing list are managed, i.e. saved. The processing speed is slowed down by a high value (>100).
- **Language.** Select the required language here. German is *standard*. All **TRADE** language files which are in the current directory are offered for selection (*.XLG).

12.2.3 Print Mode data input

- **Print Mode.** States the type of printout in the different windows. This value must be adapted according to printer.

12.2.4 Passwords data input

- **Passwords.** Enter here the operator password.

12.3 Single Scale register card (4)

This register card is divided into 3 further cards (5) - (7). The card (5) contains all not legal-for-trade parameters, the further cards (6) and (7) the legal-for-trade ones and are read only for the operator. These settings must be made separately for each connected scale. For this purpose there are 'tabs' in the upper area with which you can toggle between the scales.

Note: The scale display remains switched on during the parameter setting. Thus the scale is also switched over if a tab is activated for scale switch-over.

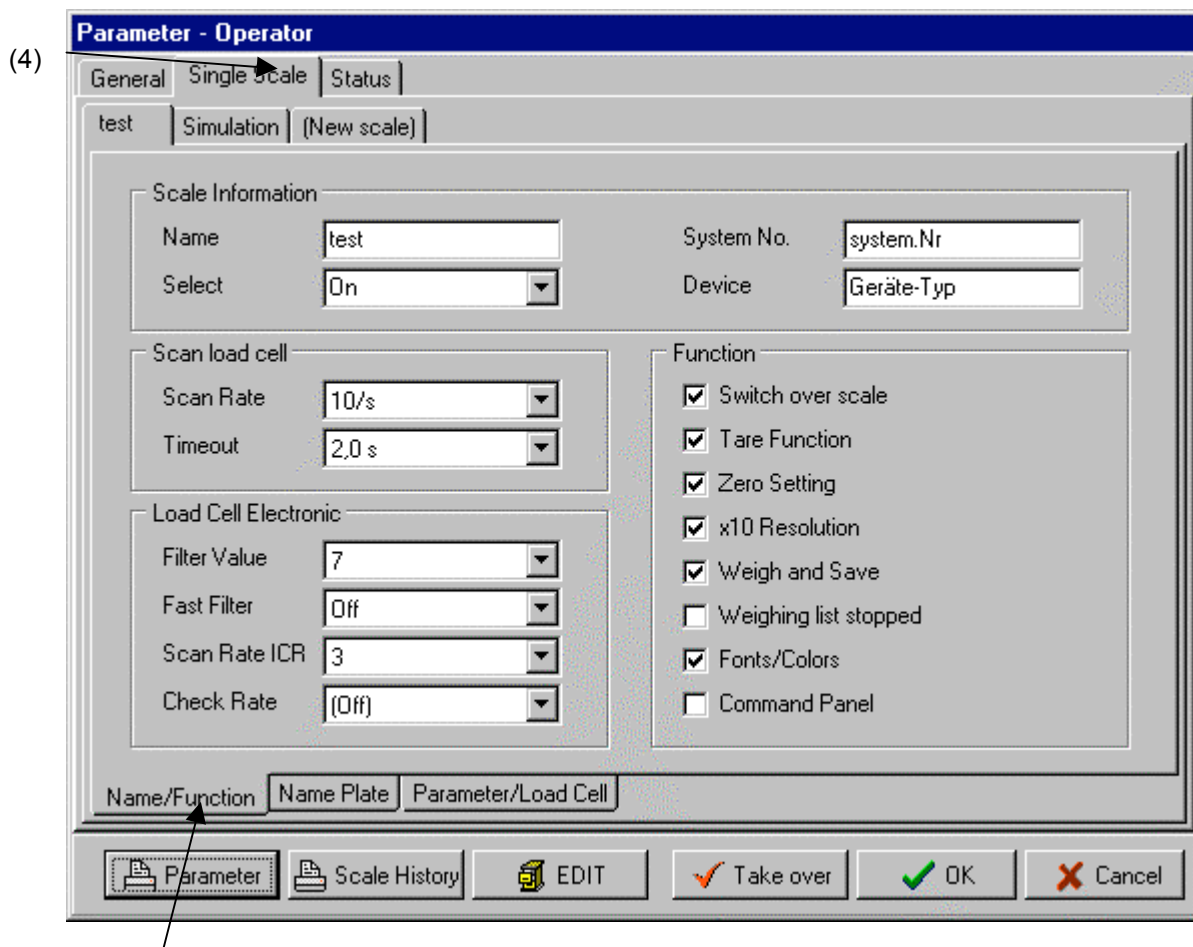

(5)

Figure 10 – Setting individual scale (Name/Function)

12.4 Name/Function register card (5)

12.4.1 Scale Information data input

- **Name.** Free text. Should clearly identify the scale. Is shown in the name plate and thus in the DSD file.
- **Select.** You can activate or deactivate the scale with this. A deselected scale cannot be used. However, its parameters are retained.
- **System-No.** Free text. Should designate the system or the area of the scale.
- **Device.** Free text. Should describe the type of the connected scale (e.g. scale type, terminal type etc.).

12.4.2 Scan data input

- **Scan Rate.** This parameter determines how frequently the connected load cell is scanned and a new weight value should be determined.
- **Timeout.** Here you define how long the system waits for data from the connected load cells. If the set time is exceeded, an error message (TIMEOUT) is displayed.

12.4.3 Load Cell Electronic data input

- **Filter Value.** States the filter of the connected load cells (*ASF*).
- **Fast Filter.** Defines the use of the fast filter algorithm (*FMD*).
- **Scan Rate.** Defines how frequently the load cell determines weight data (*ICR*).
- **Check Rate.** States how frequently a parameter of a load cell is checked during running operation.

12.4.4 Function data input

- **Function.** You define with this which keys of the menu bar (and the corresponding menu functions) can be used for this scale. Deactivated keys are visible but their function cannot be triggered.

13 Error messages and remedial action

Error message in the status line	Possible reason	Sequence of possible measures
AD error #	At least one AED electronics system no longer supplies any measured values.	Check the connection from the load cell to the AED electronics. Check the voltage supply to the load cell or electronics.
INIT error !	The scales could not be initialised correctly, e.g. the scales are connected to the incorrect COM port.	1) Reselect the scales (key F4) 2) Check COM port connection 3) Shut down TRADE and call up the TRADESCAN program – are all load cells found ? 4) Service
CHECK error!	The online check of a parameter was defective	1) Reselect scales (key F4) 2) Shut down TRADE and call up the TRADESCAN program – are all load cells found ?
Outside zero range!	The preload of the scales is outside the permitted zeroing range	1) Restart TRADE 2) Remove preload on scales
Non-perm. tara!	You attempt to tare outside the permitted range	1) Scales are overloaded – please relieve load 2) Scales in under load condition – restart TRADE
Error 216	A file searched for by TRADE does not exist	1) Check whether the directory c:\TRADE exists 2) Carry out a backup, if necessary.
CHECKSUM ERROR	The expected checksums could not be read from the load cell.	1) Reselect scales (key F4) 2) Shut down TRADE and call up the TRADESCAN program – are all load cells found ? 3) Service
Transmission error 245 Error 245	The communication with the load cell is defective	1) Reselect scales (key F4) 2) Shut down TRADE and call up the TRADESCAN program – are all load cells found ? 3) Service
DATA-TIMEOUT	The communication with the load cell is defective	Check the hardware – e.g. the power supply of the load cell

14 Installation of scales with Trade

14.1 General comments on commissioning

Commissioning a scale with digital load cells can be performed especially simply. For instance, you do not need to solder any resistors for the corner load adjustment, since this procedure is undertaken by calculation by the software.

Further you can recognize the real loading of all load cells at a glance, and thus smooth the path to immediately detecting errors in this procedure.

As the load cells work 100% separated from one another – which cannot be achieved fully with analog load cells – the factory settings of the individual load cells can be reproduced much better in the field.

14.2 Store changes finally into the load cells

If you have made changes relevant to legal-for-trade calibration, then you must store these permanently by confirming "New checksums" (Fig 11). The designated office is to be informed. Press "No" to reject again all changes.

Changes that cannot be reset in this way are interface settings such as baud rate, addresses etc., which, however, are not relevant to calibration. Only exception: if, in the case of scales with several load cells, their addresses are mixed up. This cannot be reversed again and it is relevant to calibration. Therefore, after calibration, addresses should not be exchanged among load cells.

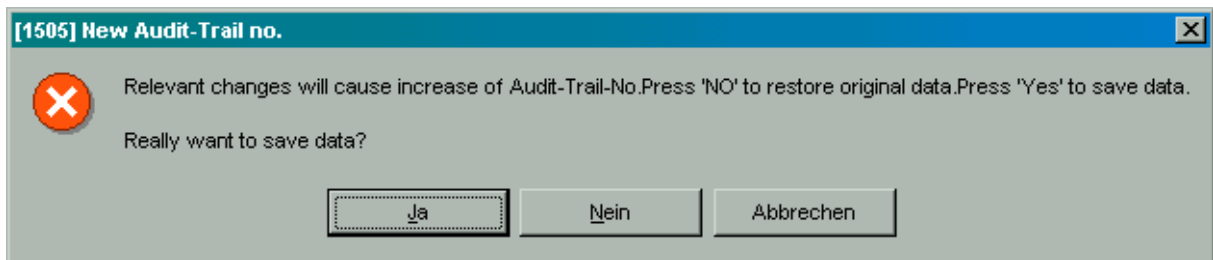

Figure 11 – New Audit Trail No.

14.3 Seriennummern der Aufnehmer

Note the serial numbers of the transducers used!



Figure 12 – Serial numbers

14.4 Parallel connection of the load cells

The parallel connection of digital load cells from HBM does not differ essentially from that with analog load cells. The connection is made by connecting the same wire colors with one another. The order of connection is not important, because this is set later on in the software. Customary terminal boxes, such as HBM VKK2-6, are suitable for the connection.

It is important that there are no active series resistors in the terminal box. Dactivate resistors R1 and R2 in the HBM terminal boxes !

Note the wiring of the connection cable to the PC so that you can make the connection to the converter more easily later on.

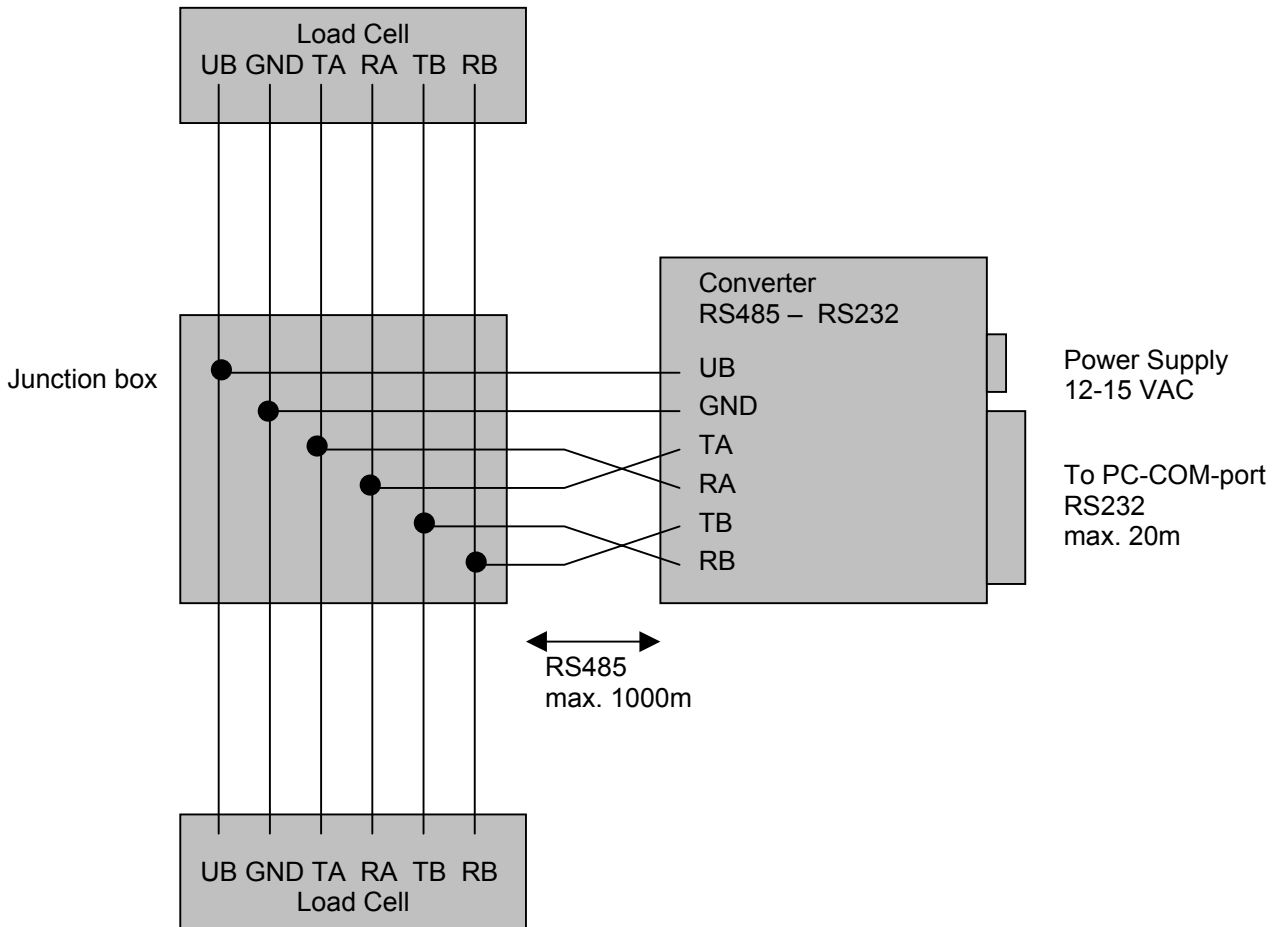

Figure 13 – Building a digital system, example with 2 load cells

14.5 Sealing the scale

If you want to construct a legal-for-trade scale, you must take the steps for sealing the scale. For sealing the scale use the seal set **1-TRADE/SEAL**. Attach the plate with the test numbers in the vicinity of the PC:

- When using digital load cells, e.g. C16i, to the cable in front of the load cell as viewed by the scale. The converter is not part of the legal chain.
- When using an **AED9101x** electronic unit, to the cable of the digital output. The **AED9101x** electronic unit must be sealed.

Attach nameplate to the cable

- Loop the cable through the large hole in the plate see Figure 16. Position the plate so that the operator of the scale can read the test numbers at any time.
- Tauten the cable so that it lies flat on the plate in the middle part. Strain relieve using the plastic ties at both ends.
- If you have a multiple scale system see the following figures:

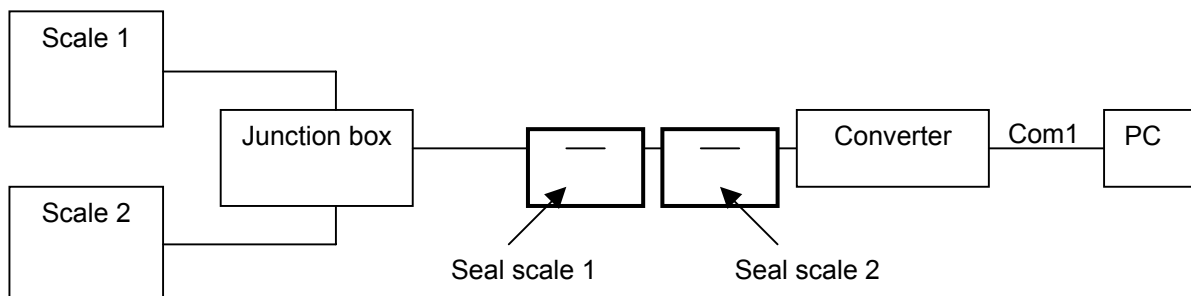

Figure 14 Sealing a multiple scale system at one COM-port

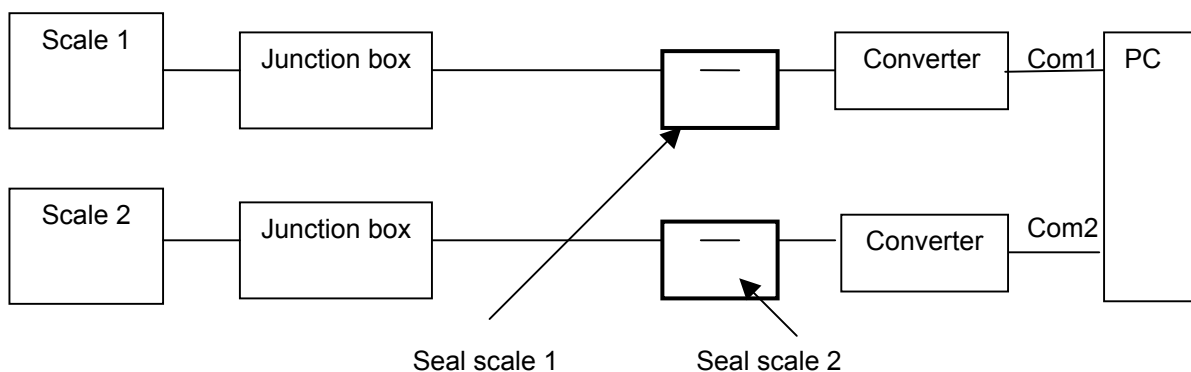

Figure 15 Sealing a multiple scale system at multiple COM-ports

Seal marks after calibration

- After calibration enter the check sums according to Figure 16 on the label. Stick the label on the cable plate. Left hand side are the check sums of the entire system (all scales). Right hand side are the check sums of the individual scales. Create a sealing plate for any individual scale.
- Attach the calibration mark (or sealing wire) so that this connects the plate and cable.
- A junction box for parallel connection of the load cells must be sealed in any event.



Figure 16 Enter check sums to the sealing label (example scale 1)

14.6 Converter connection

Before you connect the converter, perform the sealing for a legal-for-trade scale according to Section 14.5. The converter is no longer part of the legal chain. Therefore any converter which generates a RS232 signal from the RS422 4-wire signal can be connected, in order to go to a PC COM port with it. Use of the HBM converter SC232/422A, which offers additional safety by galvanic separation, is recommended.

A PC card offering a RS422 4-wire input can be used alternatively to the converter. However, you must previously check that this combination also works.

Note that the bus has to be terminated on both ends i.e. also the converter needs an active termination resistor. The HBM converter provides this resistor as standard.

14.7 Power supply of the load cells

With HBM converter SC232/422A

The power supply of the load cells can be connected directly to the HBM converter SC232/422A. Please refer to the installation instructions of the load cell for the supply that is required. Do not forget the current consumption of the converter.

Other converters

Refer to the installation instructions for the current consumption required by the load cells. Please refer to the documentation of the corresponding converter for the connection.

14.8 First Steps with TRADE

This quick instruction does not make the reading of the manual unnecessary. It only shows how to get the system running first step. You need all serial numbers of the used load cells !

Action/Field	Comment
Assemble the scale	Refer to the upper section 13
Call SETUP.EXE	Setup TRADE – follow instructions
Call TRADE.EXE	Start Program

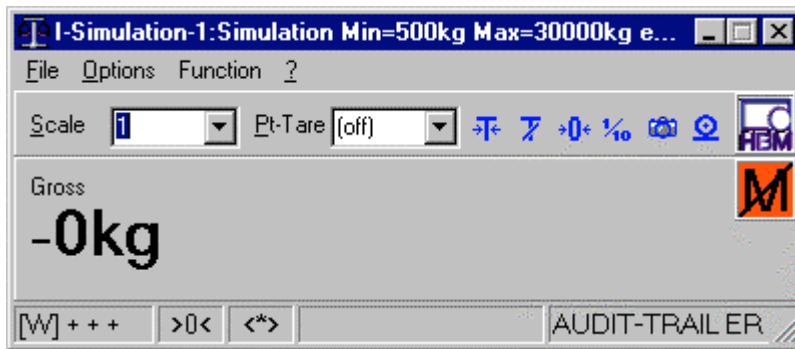

Figure 17 Trade starts with Simulation after Setup

Action/Field	Comment
Options Parameter Service	Enter service part

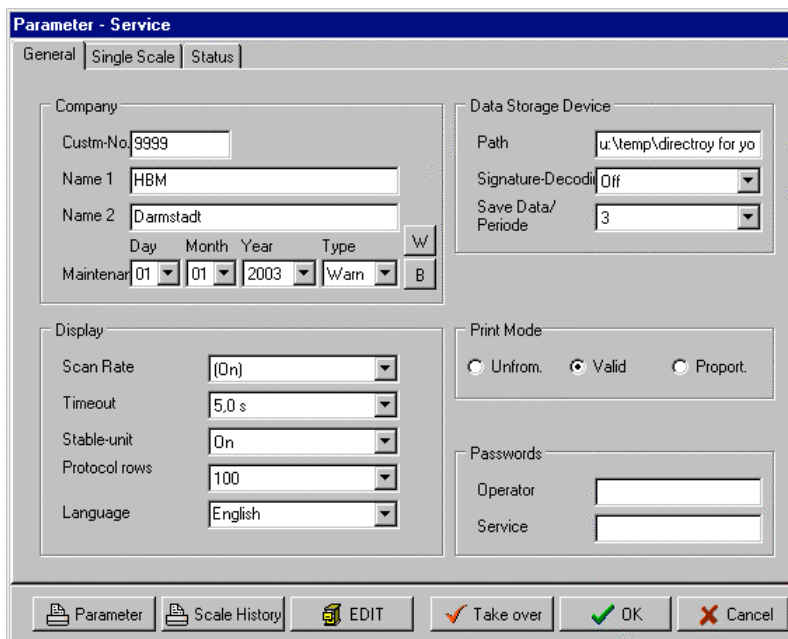

Figure 18 General parameters for all scales – parameters not legal for trade

Action/Field	Comment
Single Scale	Enter settings for the individual scales

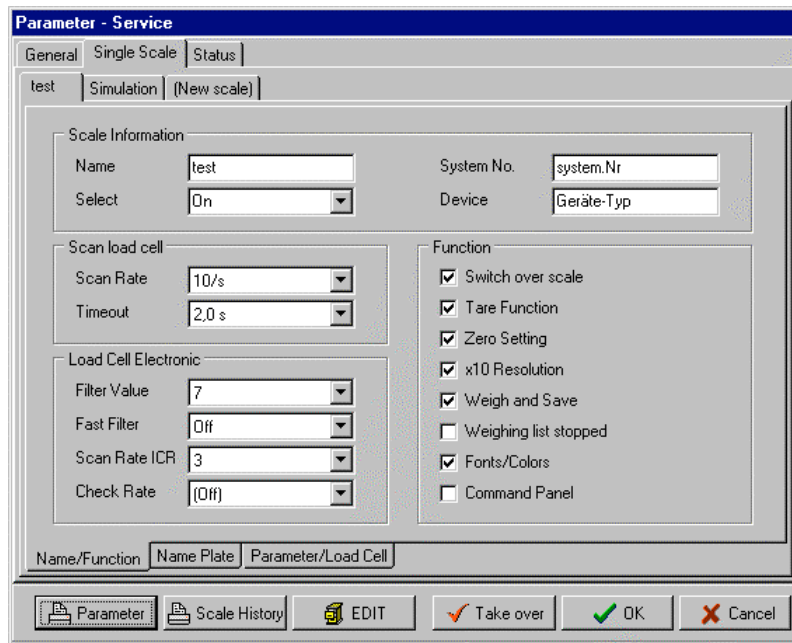

Figure 19 Single scale parameters – parameters not legal for trade

Action/Field	Comment	Example
Name	Free name of the scale	Scale1
Name Plate	Goto next window	

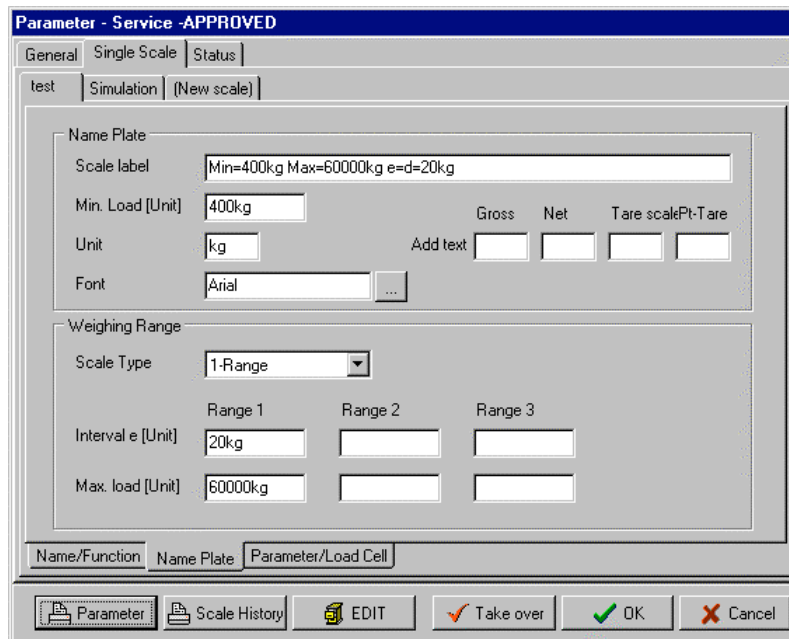

Figure 20 Name plate of the scale – all parameters are legal for trade

Action/Field	Comment	Example
Scale Label	Name plate of the scale	Min = 400kg, Max = 50.000kg, e=d=20kg
Min. Load [Unit]	Minimum scale load	400 (Legal scales after OIML Class III Min = 20e)
Unit	Weighing Unit	Kg
Interval e [Unit]	Verification Interval	20
Max. Load [Units]	Max. load of the scale	50000
Parameter/Load Cell	Goto next window	

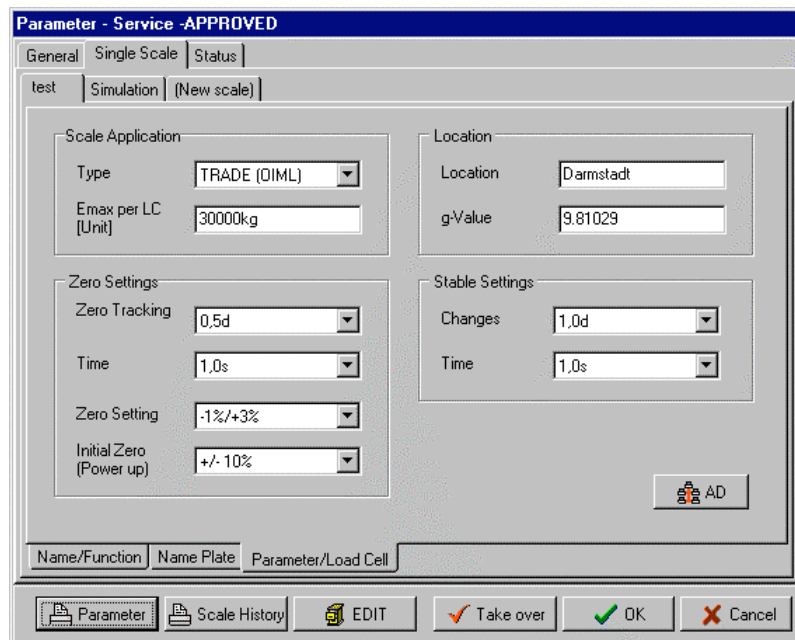

Figure 21 Parameter/Load Cell – all parameters are legal for trade

Action/Field	Comment	Example
Type	Type of the scale	Real scale requires either INDUSTRIAL, TRADE(OIML) or TRADE(NTEP)
Emax LC [Unit]	Capacity of the load cells	40000 (=40t)
g-Value	Local g-Value	Use program on CD if unknown
AD	Goto load cell window	

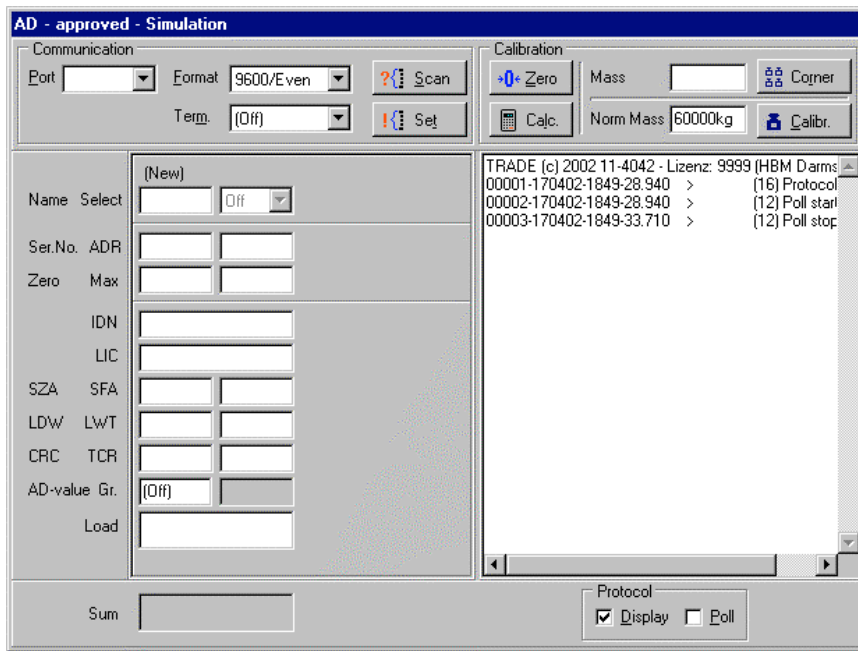

Figure 22 Load Cell overview – all parameters are legal for trade

Action/Field	Comment	Example
Accept Poll Error	Load Cells are not defined yet – poll off necessary	
Port	Communication port of the PC where the scale is connected	Com1, Com2 ... Com8
Name	Free name of first load cell	AD/1 (new load cell column will occur)
Select	Switch load cell on	ON for a desired load cells
Ser.No	Serial number of the load cell	J15303 – observe upper/lowercase letters
ADR (only necessary if more than one scale is used)	Multiple scales at one port addresses shall be set manually	00 ... 31
Repeat for all connected load cells	Whenever entering an name the next column is created	
Set	Set addresses of the load cells	

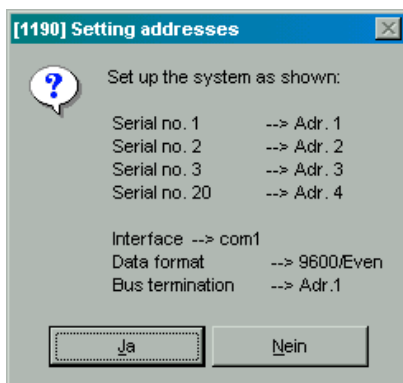

Figure 23 Proposal for automatic addressing

Action/Field	Comment
Yes	

The screenshot shows the 'AD - approved - test' software interface. It features a 'Communication' section with 'Port' set to 'com2' and 'Format' set to '4800/Even'. There are 'Scan' and 'Set' buttons. A 'Calibration' section includes 'Zero', 'Mass', 'Norm Mass' (set to 60000kg), and 'Corner' buttons. The main area is a table with columns for AD/1, AD/2, AD/3, and AD/4. The table contains various parameters for each load cell, including Ser.No., Zero, IDN, LIC, SZA, LDW, CRC, AD-value, and Load. The 'Sum' row at the bottom is highlighted in yellow and shows the value '29540*'. On the right side, there is a list of communication events with details like date, time, and status.

Figure 24 Load cell overview example 4 load cells – all relevant load cells (here 2) shall give a Load

Action/Field	Comment	Example
Poll	Activate Poll – communication with load cells	
Zero	Zero calibration of the scale	Sum shall be 0 afterwards
Calc.	Calculated calibration of span	
End	Leave window	

The screenshot shows the 'Parameter - Service - APPROVED' software interface. It has tabs for 'General', 'Single Scale', and 'Status'. The 'test' tab is active, with sub-tabs for 'Simulation' and '(New scale)'. The 'Scale Application' section includes 'Type' (TRADE (OIML)), 'Emax per LC [Unit]' (30000kg), and 'Location' (Darmstadt). The 'g-Value' is set to 9.81029. The 'Zero Settings' section includes 'Zero Tracking' (0,5d), 'Time' (1,0s), 'Zero Setting' (-1%/+3%), and 'Initial Zero (Power up)' (+/- 10%). The 'Stable Settings' section includes 'Changes' (1,0d) and 'Time' (1,0s). There is an 'AD' button at the bottom right. At the bottom, there are buttons for 'Parameter', 'Scale History', 'EDIT', 'Take over', 'OK', and 'Cancel'.

Figure 25 Again Figure Parameter/Load Cell

Action/Field	Comment
Ok	Store settings to C:\TRADE

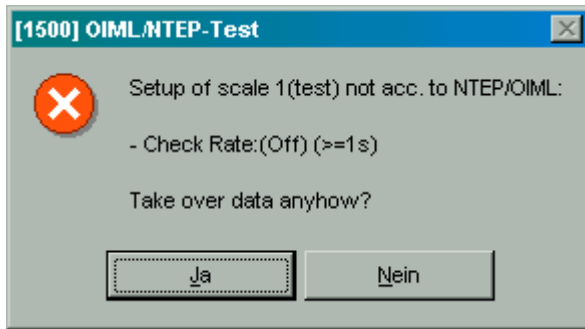

Figure 26 Warning about deviation from OIML or NTEP requirements

Action/Field	Comment
Yes	At this stage you can accept that – please change later

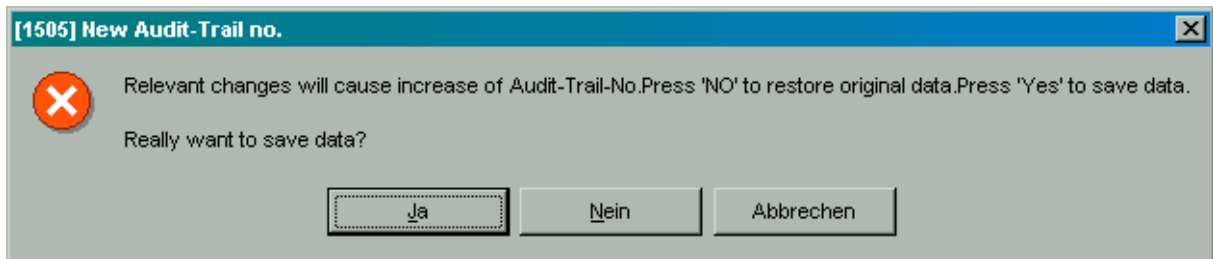

Figure 27 New Audit Trail no.

Action/Field	Comment
Yes	Accept to store the changes

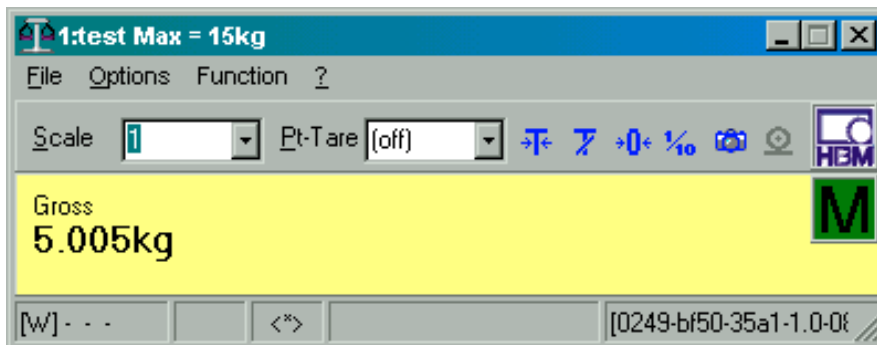

Figure 28 Trade window with running scale

Now the system works as a scale. The calibration is done by calculation, no corner adjustment done so far. To do further adjustments please refer to the manual.

14.9 Possible Problems at the Installation

No communication with the load cells	<ul style="list-style-type: none"> • Do you provide enough power to the load cells. Refer to the manual of the load cells • Is the voltage supply for the load cells between 8 .. 15 VDC ? • Are the connections load cells-converter done according to the scheme RB-TB, RA-TA, TB-RB, TA-RA • Does your connection box has active resistors as trimmers etc. Remove those • At more than 30m cable distance the termination has to be activated at any event • Restart your PC • Use the ComCheck program to test the communication
System does not react or error message at Zero/Span or Corner adjustment	<ul style="list-style-type: none"> • Unlogical values for Min, Max, Emax or Interval e
System is too slow	<ul style="list-style-type: none"> • Increase the Baud rate, activate SET • Increase the scan rate of the load cell electronic
Serial No. unknown	<ul style="list-style-type: none"> • Refer to Section 16.2.5
LC-Code Error	<ul style="list-style-type: none"> • At least one load cell contains the wrong code. Please use those load cells that fit to that software version.

15 Options - Parameter

Main Menu → Options → Parameter → Operator

Main Menu → Options → Parameter → Service

Password. The user password is required for the 'User' area. No legal-for-trade parameters can be changed with this. You require the service password to change the *legal-for-trade parameters*. All changes are possible with this.

If several sessions of TRADE are active, only those parameters of the scales can be changed, by means of which you carry out service access. However, this also allows maintenance work to be carried out on one set of scales, and the other scales to be operated normally. In this case, the general parameters are not to be altered. For this purpose only one session may be active.

Note that changes in the legal-for-trade area change the checksums and thus a possibly existing calibration is annulled.

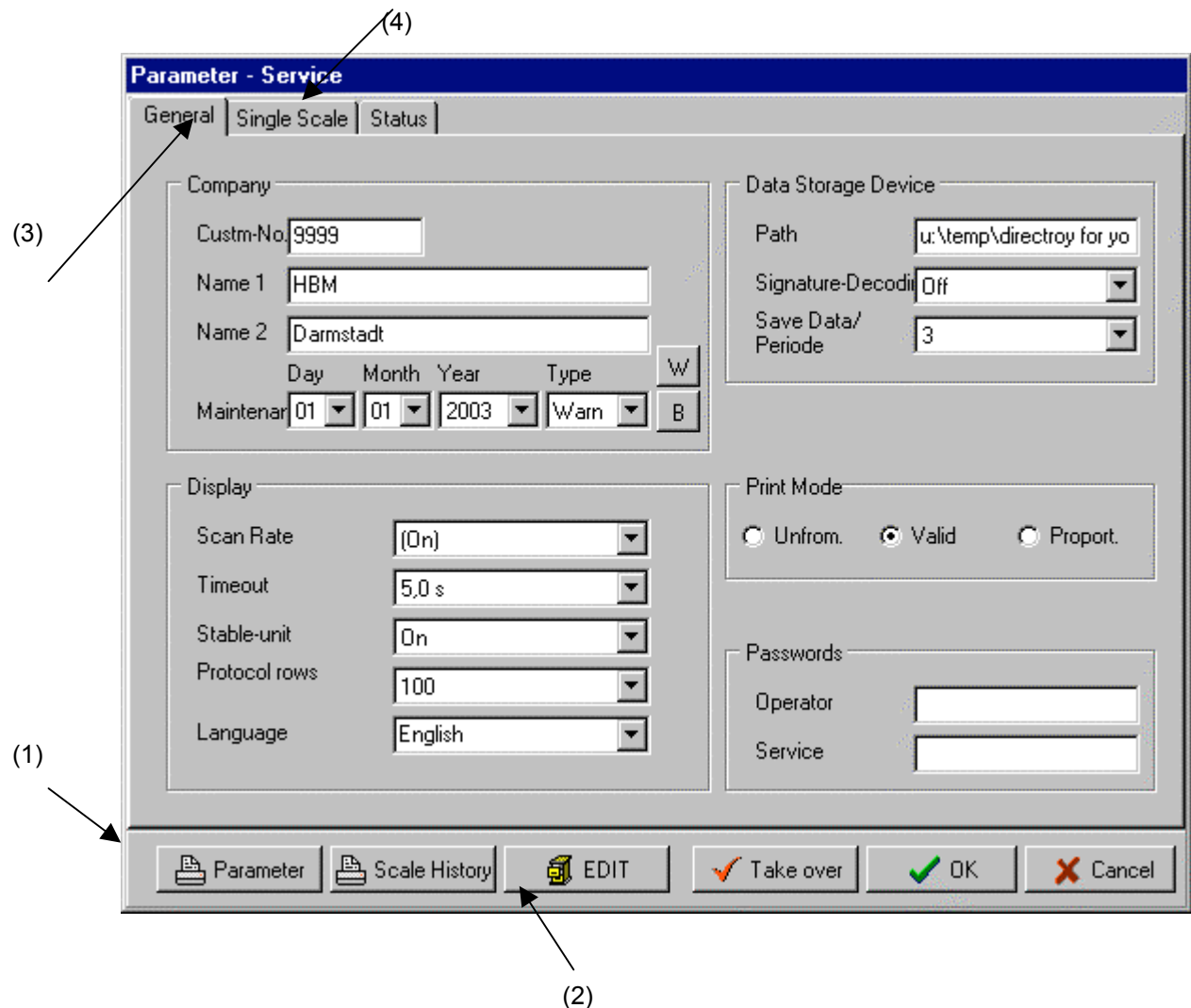

Figure 29 - 'General' parameter setting for all scales

15.1 Functions of the foot row (1)

- **'Parameter' button.** After this button is activated, the complete settings (legal for trade and not legal for trade) of all existing scales are displayed and optionally printed. Data is copied to the clipboard for further use e.g. email etc.
- **'Scale History' button.** After this button is activated, the scale history is displayed and optionally printed. Data is copied to the clipboard for further use e.g. email etc.
- **'Take Over' button.** As for *OK*, but the window is not exited. The scale is nevertheless set to the changed values, so that these can be checked.
- **'OK' button.** The changed data are saved. If changes have been made in the legal-for-trade area, a corresponding note appears.
- **'Cancel' button.** All previously performed changes are rejected after a prompt.

Note: The following changes in the *load cell setting* area cannot be undone since they are stored directly in the load cell:

- Address setting
- Setting of the interface
- Setting of the baud rate

If changes of this type have been made, the *Cancel* button is disabled and a warning note appears.

15.1.1 EDIT Context menu by means of right mouse button (2)

A context menu with further functions appears after the right mouse button is pressed over the foot row:

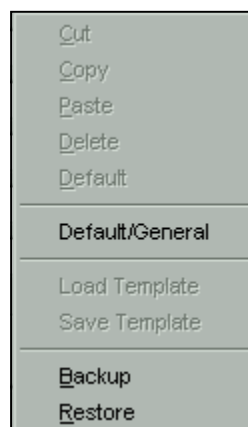

Figure 30 – Context menu

- **Cut.** Combination of *Copy* with subsequent *Delete*.
- **Copy.** You can copy all settings of the current scale into the clipboard with this.
- **Paste.** You can copy previously copied settings to the current scale with this.
- **Delete.** All parameters of the current scale are deleted with this.
- **Default.** All parameters of the current scale are reset to standard values. This does not concern the setting of the load cells or the calibration.
- **Default/General.** The parameters of the *General* register card are reset to standard values.
- **Save Template.** All parameters of the current scale are saved in a file. The file has the extension '.SCH'. With this you have the possibility of saving presettings for certain scale types in order to reuse them later.
- **Load Template.** Parameters saved previously are copied to the current scale.
- **Backup.** All files of the \TRADE directory are copied onto a required data medium.
- **Restore.** All files of the \TRADE directory are loaded back from a required data medium. In this case the current settings are deleted irrevocably!

15.2 General register card (3)

Settings for the total system possibly consisting of several scales are made here.

15.2.1 Company data input

- **Custom. No./Name1/Name2:** States the customer name and address.
- **Maintenance:** Input the maintenance date. The maintenance message will only become active, if a service password is entered. The timing for the messages is fixed and can be found in Chapter 10. TRADE knows two different modes of maintenance, for which you can provide and store different texts. To this end, you click on the symbols "W" or „B". The texts are located in the directory \TRADE in the files trade_w.srv and trade_b.srv. However, these can also be edited by means of an editor.
Using the program TRADESERVICE.exe, which can be found on the TRADE CD, you can calculate the maintenance code, which deactivates the warnings or blockages. For this purpose, a service password is required. At the same time you can use this code to activate a different mode and set a new maintenance date.
- **Warning (W):** Here, the user is only prompted to do something. The scales continue to function. A meaningful text might be e.g.: "One of your scales must be re-calibrated at the a/m date. Please contact company XYZ, tel. 06151/8030"
- **Blockage (B):** One week after the scheduled date has expired all scales within the system will be blocked. The display "BLOCKED" appears. A meaningful text might be e.g. "The licence for the leasing scales expires on the a/m date. The scales are blocked one week after expiry. Please contact company XYZ, tel. 06151/8030"

The screenshot shows a dialog box titled "TRADE - SERVICE". It has a blue title bar with a close button. The main area is grey and contains several input fields and controls:

- Servicepassword:** A single-line text input field.
- Mode:** A dropdown menu with a question mark icon to its right.
- Day Month Year (Left):** Three dropdown menus for Day, Month, and Year, with an orange arrow pointing to the right.
- Day Month Year (Right):** Three dropdown menus for Day, Month, and Year.
- Code:** Four small text input fields.
- Check:** Two text input fields.
- Icons:** A printer icon, a calculator icon, and a help icon (question mark in a circle).

Figure 31 – ProgrammTRADESERVICE.exe for calculating the maintenance code

15.2.2 DSD-File data input

- **Path.** Reproduces the directory for the DSD file.
- **Signature.** States how the signature is displayed, transferred and saved:
 - Off (Date legible):** Date - checksum - time - e.g. 120197-ABCD-235523
 - On (Hex-coded):** D/U1 - checksum - D/U2- e.g. XZ9-ABCD-O1P
Date and time are scrambled bit-wise so that the date cannot be derived from the data record. This is expedient if date/time of the weighing should be hidden (e.g. on a delivery note).
- **Save Data/Period.** States how long calibration data should be saved (minimum value is 3 months).

15.2.3 Display data input

- **Scan Rate.** States how frequently the weight display should be updated. (*On*) means that the display is updated for each new data record.
- **Timeout.** States after which time the weight display is switched off if no further scale data are present (e.g. because the connected load cells do not respond).
- **Stable/Unit.** States whether the unit (e.g. *kg*) should be masked out in the case of scale unstable.
- **Protocol rows.** States how many rows in the weighing list are managed, i.e. saved. The processing speed is slowed down by a high value (>100).
- **Language.** Select the required language here. German is *standard*. All **TRADE** language files which are in the current directory are offered for selection (*.XLG).

15.2.4 Print Mode data input

- **Print Mode.** States the type of printout in the different windows. This value must be adapted according to printer.

15.2.5 Passwords data input

- **Passwords.** Enter here the operator password or the service password.

15.3 Single Scale register card (4)

This register card is divided into 3 further cards (5) - (7). The card (5) contains all not legal-for-trade parameters, the further cards (6) and (7) the legal-for-trade ones. These settings must be made separately for each connected scale. For this purpose there are 'tabs' in the upper area with which you can toggle between the scales. The last 'tab' in each case is labelled with *(New scale)*. Activate this to include a further scale in your system.

Note: The scale display remains switched on during the parameter setting. Thus the scale is also switched over if a tab is activated for scale switch-over. In the case of a new scale it is expedient to activate the scale selection (see below) only if all parameters are set completely.

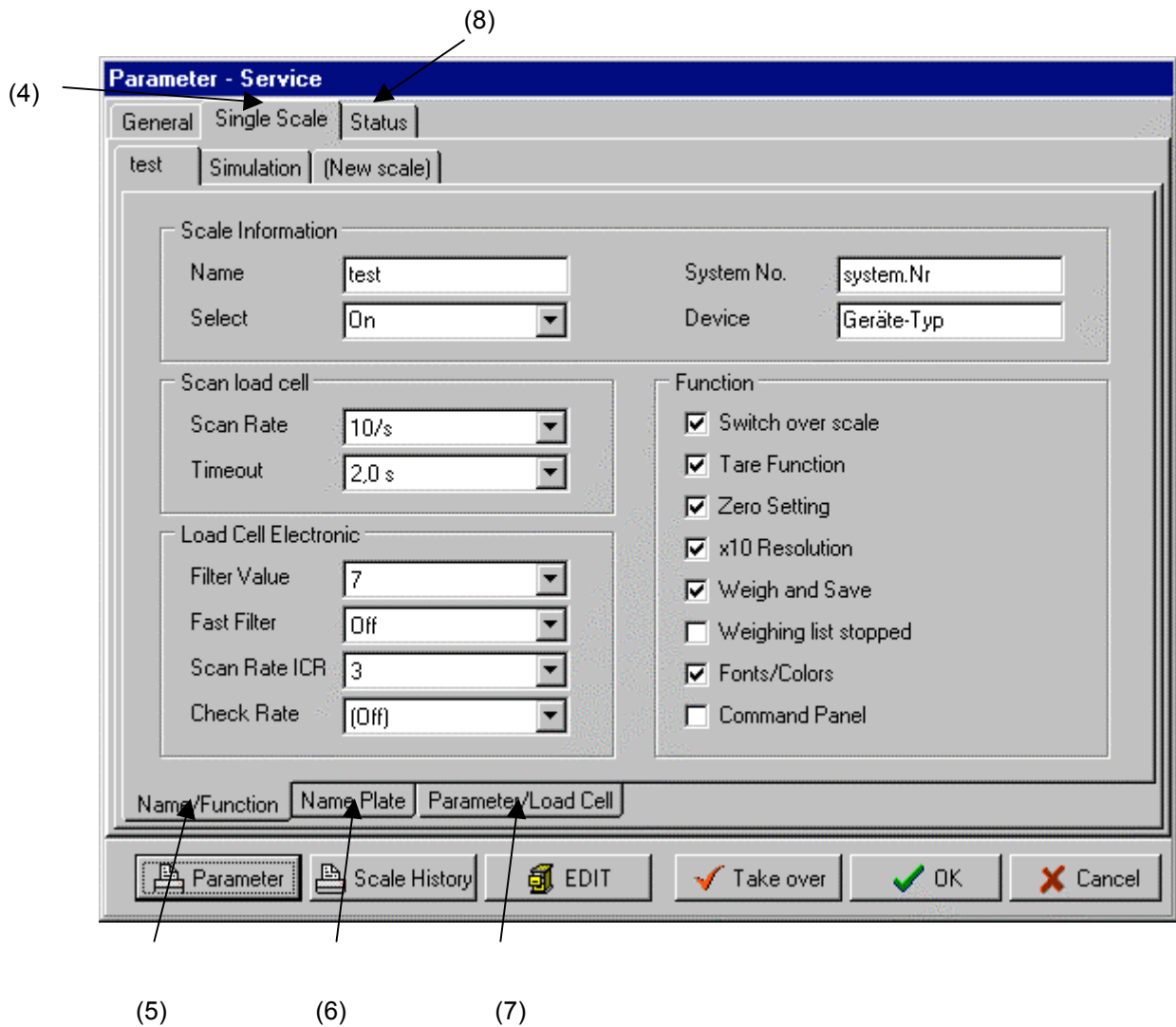

Figure 32 – Setting individual scale (Name/Function)

15.4 Name/Function register card (5)

15.4.1 Scale Information data input

- **Name.** Free text. Should clearly identify the scale. Is shown in the name plate and thus in the DSD file.

- **Select.** You can activate or deactivate the scale with this. A deselected scale cannot be used. However, its parameters are retained.
- **System-No.** Free text. Should designate the system or the area of the scale.
- **Device.** Free text. Should describe the type of the connected scale (e.g. scale type, terminal type etc.).

15.4.2 Scan data input

- **Scan Rate.** This parameter determines how frequently the connected load cell is scanned and a new weight value should be determined.
- **Timeout.** Here you define how long the system waits for data from the connected load cells. If the set time is exceeded, an error message (TIMEOUT) is displayed.

15.4.3 Load Cell Electronic data input

- **Filter Value.** States the filter of the connected load cells (*ASF*).
- **Fast Filter.** Defines the use of the fast filter algorithm (*FMD*).
- **Scan Rate.** Defines how frequently the load cell determines weight data (*ICR*).
- **Check Rate.** States how frequently a parameter of a load cell is checked during running operation. The following parameters of the **AD10x** are checked:

IDN, ADR, STR, COF, TEX
 NOV, ASF, FMD, ICR
 SZA, SFA, LDW, LWT, LIC
 TAV, TAS, ZTR, ZSE, CRC, TCR

It results from this that 20 parameters are checked per load cell. Correspondingly the

Cycle time = number of load cells x 20 x checking interval.

Note: If a parameter error is determined during the check, this is displayed in the status row with the **CHECK** message. This message disappears if a cycle has been run through completely free of error.

Note: To use the *load cell* parameters, please also use the Manuals of the connected load cells (e.g. **AD10x**).

15.4.4 Function data input

- **Function.** You define with this which keys of the menu bar (and the corresponding menu functions) can be used for this scale. Deactivated keys are visible but their function cannot be triggered.

15.5 Name Plate register card (6)

Settings in this area are subject to the legal-for-trade requirements

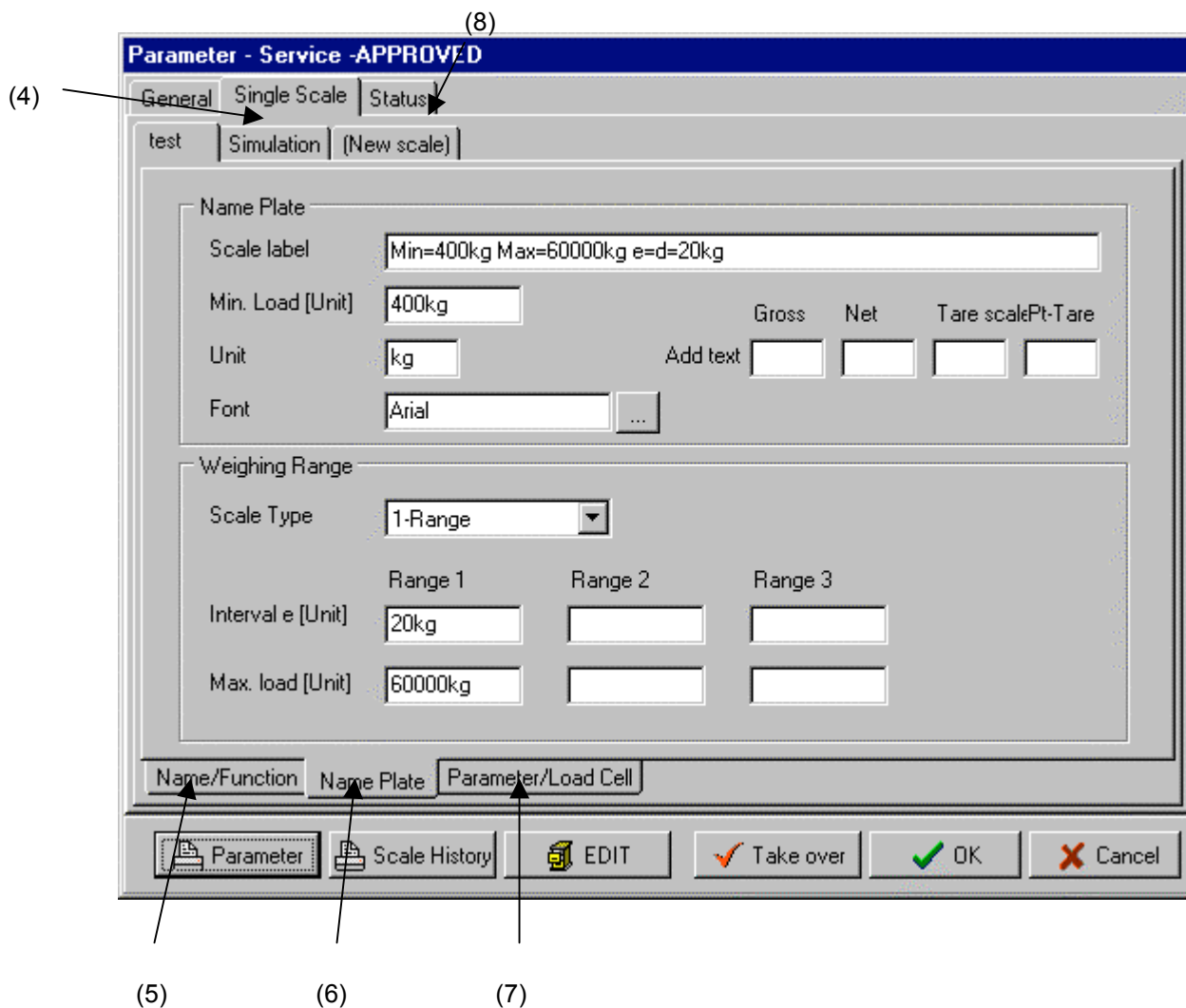

Figure 33 – Setting of individual scale (Name Plate)

15.5.1 Name Plate data input

- **Scale label.** Defines the display of the name plate (header of the display window). Content of that string is not further used.
- **Min. Load [Unit].** Define the minimum load of the scale in the current weight unit in each case.
- **Unit.** Define the weight unit.
- **Addition.** Here you define an additional text which is appended to the weights (separately for gross, net, tare or manual tare).
- **Font.** Here you set which font should be used if the operator changes the font of the weight display. This font must be legible, i.e. no graphic fonts etc. may be selected. You obtain a selection menu with a double-click!

15.5.2 Weighing Range data input

- **Scale Type.** Here you define the operating mode in which the scale should work. The following fields (*Division*, *Max*) can be entered according to setting.
- **Interval e [Unit].** Enter for every possible weighing range the division of the scale e (as weight value / unit).

- **Max. load [Unit].** Enter here the maximum load for the relevant weighing range (or the maximum load of the scale for the last weighing range). Observe that here as well the actual maximum weight (and not the number of the digital steps) must be entered.

15.6 Parameter/Load Cell register card (7)

Settings in this area are subject to the legal-for-trade requirements

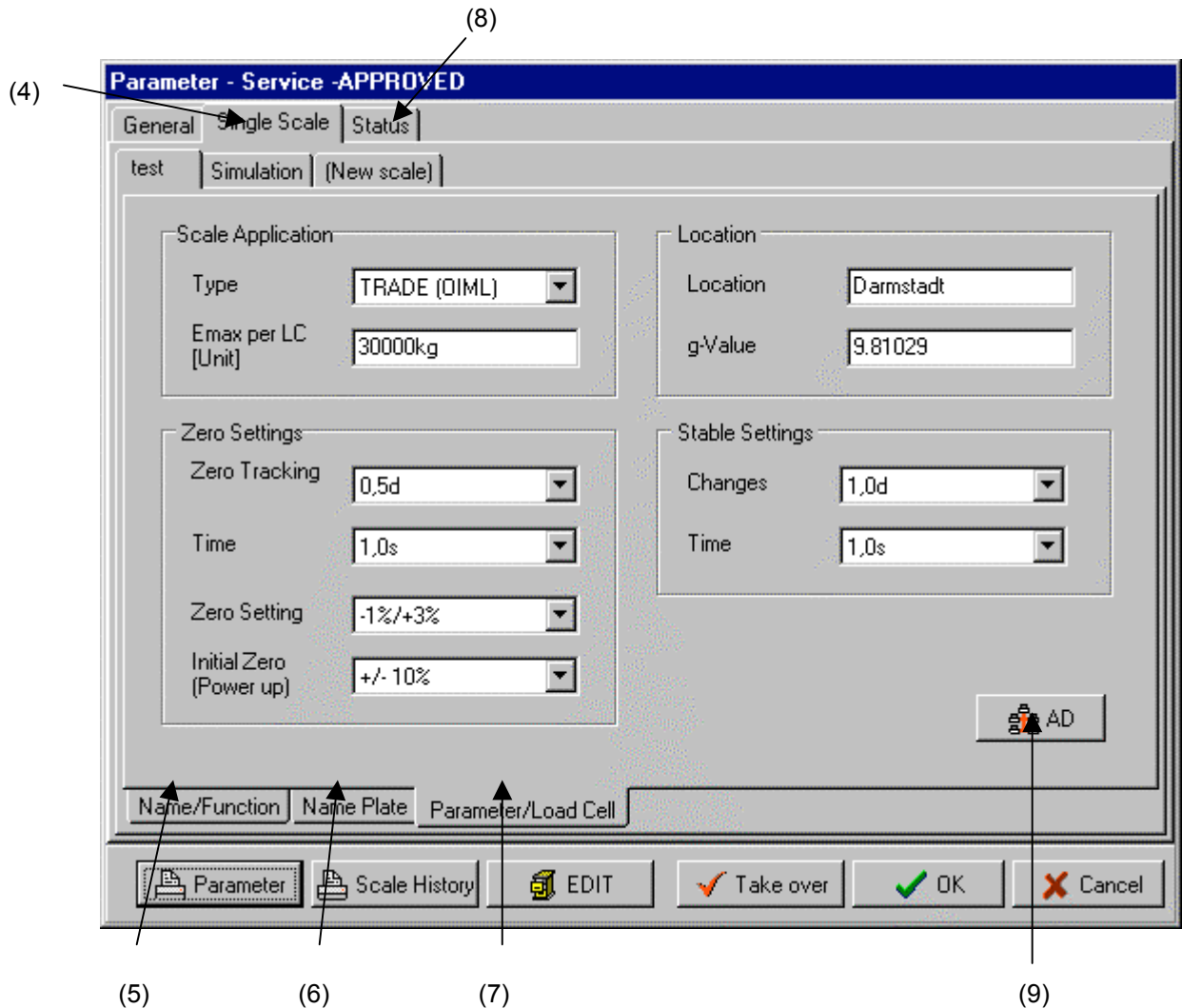

Figure 34 – Setting of individual scale (parameter/load cell)

15.6.1 Scale Application data input

- **Type.** You define the operating mode of the scale with this. The following settings are possible:

Industrial: All parameters can be set arbitrarily, since the scale is not subject to any legal-for-trade regulations.

Trade/OIML: The scale works legal for trade according to OIML. In this case various restrictions (e.g. in the area of stable, zero, overload) must be observed.

Trade/NTEP. The scale works legal for trade according to NTEP. The restrictions correspond essentially to those according to OIML.

Simulation. The scale works in the simulation mode. All parameters are allowed. Possibly connected load cells are not scanned, but the weight can be set manually in the simulation window Chap. 8.

Note: When using the *TRADE/OIML/NTEP* operating modes, all legal-for-trade parameters are checked before saving. In the case of a deviation a corresponding message appears.

- **E_{max} LC [Unit]**. Here you define the nominal load of the used load cells. This value is used in the calculatory adjustment.
Using analog load cells in connection with **AED9101x** the sum of nominal load has to be given.
E.g.: 3 Load cells á 20.000 kg, enter 60.000

15.6.2 Location data input

- **Location**. Name of the location. Not used in the program.
- **g-Value**. Determines the g-factor for the relevant location. This value is used in the calculatory adjustment. If it is not stated, Darmstadt (g= 9.81029 m/s²) is assumed here. In order to calculate your local g-factor the following equation can be used:

$$g \text{ [m/s}^2\text{]} = 9,80632 - 0,02586 \cdot \cos(2 \cdot \varphi) + 0,00003 \cdot \cos(4 \cdot \varphi) - 0,00000293 \cdot h$$

φ = Latitude in rad; Example: Frankfurt 50°, Value = 0,87266463

h = Height over sea level in meter; Example: Frankfurt = 150 m

g-factor for Frankfurt: 9,81034 m/s²

15.6.3 Stable Settings data input

- **Changes / Time**. Here you define how the stable criterion is defined. This can be defined separately for a weight and time range. The scale is considered to be *stable* if the weight changes within the set time maximally by the set value.

15.6.4 Zero Settings data input

- **Zero Tracking / Time**. The automatic zero tracking works in the range set by *Range* and *Time*. In this case zero tracking takes place if the weight is also inside the set weight range within the set time.
- **Zero Setting**. Here you define in which range the scale can be zeroed.
- **Initial Zero**. States in which range the scale can be zeroed automatically after the first power up.

15.7 Status card (8)

Parameter - Service

General | Single Scale | Status

Parameter

Check-Sum

1=[0061-5e96] D.K.

Software

Check-Sum

9df0 D.K.

Version

1.1-01.02.02 D.K.

Comment

1

2

Load Cell Overload

2

Parameter Scale History EDIT Take over OK Cancel

Figure 35 – Check window for service

Here it is possible to see the program version and the associated checksums. If one or several entries are marked with 'CHANGED', the audit trail counter is displayed at all relevant program places as '????'. The following actions are performed by activating the 'OK' button:

- New calculation of all checksums
- Increasing the audit trail counter
- Entry in the DSD file which logs the change ([PUT]).

Observe that a change or acknowledgement of the changed checksums must be notified to the responsible authorities!

In the Load Cell Overload window, overloads of the load cells are summed. This is the case as a rule at **110%** of the load cell nominal load. It can be determined in the display of the scale history (events) when and for which load cells the overload has taken place. For this purpose search for the RANGE events, see also Section 16.4

16 Setup Load Cells

For this activate the *AD* button on the *Parameter/Load Cell* register card, see Fig. 10, Item (9). Settings in this area are subject to the legal-for-trade requirements.

The screenshot shows the 'AD - approved - test' software interface. It is divided into several sections:

- Communication:** Port: com2, Format: 4800/Even, Term: (Off), Scan, Set buttons.
- Calibration:** +0 Zero, Mass, Norm Mass: 60000kg, Corner, Calibr. buttons.
- Load Cell Parameters Table:**

	AD/1	AD/2	AD/3	AD/4
Name Select	AD/1	AD/2	AD/3	AD/4
Ser.No. ADR	2494 01	2518 02	2517 03	2487 04
Zero Max				
IDN	HBM,Pw6 MKR4 15	HBM,Pw6 MKR4 15	HBM,Pw6 MKR4 15	HBM,Pw6 MKR4 15
SZA SFA	-0007643 0901930	0008924 0911909	-0007998 0904477	-0006798 0889705
LDW LWT	0 1000000	0 1000000	0 1000000	0 1000000
CRC TCR	0050112 0000031	0050112 0000031	0050112 0000031	0050112 0000034
AD-value Gr.	0001707 102	0223792 13428	0264457 15868	0002366 142
Load	52	6714	7934	70
Sum	29540*			
- Log Window:** A list of data transmission records with columns for ID, direction (SND/RCV), and status.
- Protocol:** Display, Poll checkboxes, End button.

Figure 36 – Load cell setting

16.1 General

Up to 16 digital load cells per scale can be connected. For their use we refer to the Manual of the relevant load cell.

You have the following setting possibilities in this window:

- Selection of the interface, of the data transmission format and of the bus termination
- Setting the name, the selection, the address and the serial number of each load cell
- Scan of or searching for existing load cells (Scan)
- Zero point adjustment
- Adjustment without weights
- Adjustment of the scale with normal masses
- Corner adjustment (calibration) using 2 or more load cells
- Display of the digital values or of the standardized weight values of each load cell as well as of the total value (weight value)
- Display of the data transmission in a log window

In our example four load cells (four corners) are connected together for one weighing system.

Notes:

- If only one load cell is used, a corner adjustment can be dispensed with.
- During the display of this window, the 'normal' weight display is switched off.
- A large filter time is set and the scan rate is 4/s.

- By double-clicking in the relevant range, these are set to the optimum size. You can change as customary the window size and using the slide between the regions the size of the regions.
- Should reading errors occur (e.g. because no load cell is connected yet), the system may be very inert. In this case switch off the *Poll* of the load cells.

16.2 Communication window(1)

16.2.1 Interface parameters

- **Port.** Interface of the PC from COM1 up to COM8
- **Format.** Baud rate and parity. System means that the PC setting is used. All load cells are set to the stated values.
- **Term.** Address of the load cell the bus termination of which should be activated.
Note that the bus has to be terminated on both ends i.e. also the converter needs an active termination resistor. The HBM converter provides this resistor as standard.
-

16.2.2 Setting the interface

Enter the interface parameters as described above. So that these are saved for **HBM TRADE** and in the load cells, you must subsequently select the *Scan* or *Set* function.

Note: Enter the address of the load cell which should activate the bus termination. With all other load cells this is then switched inactive. In this case at the start of the process all terminations are initially inactive, which can lead to problems in extreme conditions (e.g. cable length). Then proceed as follows:

- Reduce the baud rate temporarily
- Connect the load cells individually and set the termination manually or
- Terminate externally, i.e. by use of a termination network for the last load cell.

16.2.3 Scan – Determining the connected load cells

The scan serves for

1. determining all connected load cells or
2. to determine the setting anew for the already set load cells

After the button is activated a query with which you decide how you want to continue appears.

1. Determine anew:

If the load cells used have already been used previously (i.e. the setting of the address is unequivocal), it is possible simply with this function to assign the load cells to the current scale. To determine the connected load cells, these are set initially to the current baud rate. It is then checked for all possible addresses (0..31) whether a load cell is connected. This is displayed. Then change the names as required.

Note: All calibration data are deleted in this function!

2. Read parameters anew

To determine, for instance, whether all load cells can be addressed, it is possible to scan all already entered load cells and to read their parameters. Load cells which are not present are marked *Off* in this case.

Note: All calibration data are retained with this function.

16.2.4 Set – Determining the addresses

If the load cells were not used previously, their parameters stand at factory setting (e.g. address 31). It is thus necessary to allocate unequivocal addresses by reference to the serial number. Enter for each load cell apart from a free name also the serial number and optionally the required bus address in the window (2). Activate the determined load cells with "ON". Then activate the *Set* button. Decide firstly

whether you want to allocate the addresses automatically (in this case you can dispense with entering the addresses) or whether the entered ones should be used. The following display then appears:

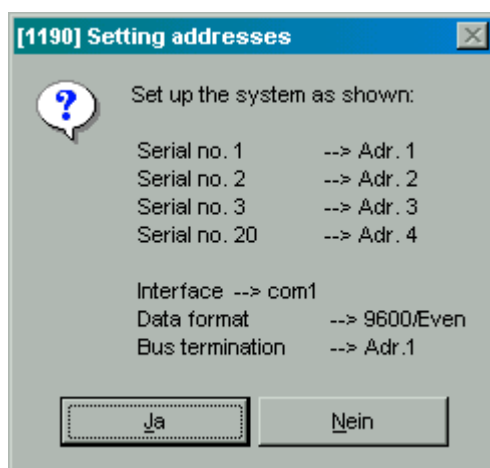

Figure 37 – Address allocation for load cells

HBM TRADE shows you how the addresses are set. After successful address setting there is automatically a *Scan* which determines all parameters of the active load cells.

16.2.5 Unknown serial numbers

If a *Scan* is not possible (e.g. because all load cells stand at factory setting = address 31) and if the serial numbers are also not known, you must connect the load cells individually and determine the serial numbers by means of a *SCAN*. Continue subsequently with the address setting.

16.3 Load Cell Parameter window (2)

The following parameters are displayed / entered here for each connected transmitter:

- **Name.** Allocate a name which describes the load cell as accurately as possible (e.g. front left, back left) etc. A name must be entered in any event.
- **Select.** Here you determine whether a load cell belongs to the current scale. If the selection is *Off*, the load cell is not taken into account in the weight determination and in the corner adjustment. This is expedient if, for instance, eight load cells are operated in the bus, of which in each case four are assigned to a scale. This parameter is set automatically in the *Scan* and in the *address setting*.
- **Ser. No.** Here you enter the serial number of the load cell. This parameter is set automatically in the *Scan* (part of the *IDN* parameter).
- **ADR.** Enter here the address of the load cell. This parameter is set automatically in the *Scan*.
- **Zero. Max.** Internal characteristic parameters. These are set during the adjustment.
- **IDN,LIC,SZA,SFA,LDW,LWT.** These parameters are determined by the *Scan* or by the calibration. They cannot be entered manually.
- **CRC,TCR.** Checksums and audit trail counters.
- **AD-Value.** States the currently determined value of the relevant load cell. This value lies between 0 and 1,000,000.
- **Gr (Gross):** Shows the individual gross value of the load cells. Shall be close to zero if the scale is empty.
- **Load.** The gross value shows the real load of the load cells. Using analog load cells in connection with **AED9101x** the total load of the scale is shown

Note: In each case the last load cell receives the header (*New*). Thus it is possible simply to add further load cells manually. If a name is input for this, a further load cell is automatically generated (max. 16).

16.4 Log window (3)

All data records and various calibration information is logged in this area. The following information is displayed:

- Serial number
- Time since start (hours, minutes, seconds, milliseconds)
- Type of the message
 - SND – Data record sent
 - RCV – Data record received
 - SCAN – Event scan
 - CAL – Event calibration/adjustment
 - INIT - Initialization
 - RANGE – Load cell overload more than 110% (1.1 Mio digit)
 - I-WG – Scale initialization
 - I-AD – AD initialization
 - I-ER – Initialization error
 - I-OK – Initializing OK
 - PUT – New Checksum written into the load cells
- Number of the characters in the message
- Message (according to type)

Furthermore you have the possibility of marking areas of the display in order to save these in the clipboard, for instance.

16.5 Footer (4)

- **Sum.** Corresponds to weight for an adjusted scale without zero point.. The resolution is 10 time higher than standard. Addition “*” means stable signal.
- **Protocol-Display.** Switches the protocol display on or off.
- **Poll.** Switches the weight determination (polling the load cell) off.

16.6 Calibration window (5)

The order of adjustment routines is shown below. A different order may overwrite previously performed calibrations. The zero adjustment can again be performed anywhere in the process w/o touching other calibrations.

16.6.1 Zero Adjustment

Activate the *Zero* button. The Zero adjustment is done w/o weight limits. This has to be the first step in a calibration routine. Scale has to be empty of course.

16.6.2 Calculated Adjustment w/o Weights

Activate the *Calc* button. Corresponds to a computer adjustment. The scale is adjusted by calculation from the nominal load of the scale (see Section 15.6.1) and the local g factor (see Section 15.6.2) and the scale parameters. Depending upon the accuracy of the factory adjustment of the load cells, accurate adjustments – without weights – are already possible here.

! Caution: A corner adjustment or calibration; possibly performed previously; is thus invalidated !

16.6.3 Corner Adjustment

The corner adjustment is used if more than one load cell are connected together to form a scale. In this case the load cells are adjusted so that the resulting total weight is independent of the load distribution on the scale.

! Caution: A calibration possibly performed previously is thus invalidated !

Note: Observe that you must work both in the adjustment and in the corner adjustment with weights which are at least 2% of the nominal scale load (As a rule legal for trade scales require much bigger testing weights than 2%).

Proceed as follows:

- Do a Zero adjustment first if not done yet
- Enter the calibration load (*Mass*). If you enter the exact load (own weight), a subsequent adjustment is no longer necessary. If the load is not known, you should enter the nominal load of the load cell in order to obtain an expedient gross weight display during the corner adjustment. If both values are missing, it is assumed that the nominal load corresponds to the scale maximum load (which, however, is generally not the case).
The mathematics requires that each corner is loaded separately. Thus testing the corners with a vehicle as wide as the bridge is not possible.
- Now load the corners (= load cells) one after the other. In this case the next load cell in each case is displayed in the button. If a load cell other than the required one is loaded, a warning message appears. In this case the process must be repeated or cancelled. Order of corner testing can be changed with the right hand side mouse button activated over the corner button.
- During the process this can be cancelled at any time with the *END* button.
- After all weights have been determined, the program calculates the parameters for all load cells and stores these. If the calculation or storage is not possible (e.g. because the span is too low), an error message appears.

Note: Observe that you must work both in the adjustment and in the corner adjustment with weights which are at least 2% of the nominal scale load MAX. LOAD. (As a rule legal for trade scales require much bigger testing weights than 2%).

16.6.4 Calibration

If only one load cell is available or if the corner adjustment was made with an unknown weight, the scale must be adjusted. Proceed as follows:

- Do a Zero adjustment first if not done yet
- State the adjustment load (the actual weight of the load = calibration weight) in the *Norm Mass.* field.
- Activate the *Calibration* button. Follow the instructions.

Note: Observe that you must work both in the adjustment and in the corner adjustment with weights which are at least 2% of the nominal scale load MAX. LOAD. (As a rule legal for trade scales require much bigger testing weights than 2%).

17 Trade on the PC

TRADE requires a standard PC w/o any legal for trade restriction as the PC is not part of the approved chain. For PC requirements refer to the **TRADE** data sheet.

17.1 Installation of **TRADE**

TRADE is delivered on CD. It contains apart from the main EXE file further documents as manuals etc. Start SETUP.EXE and follow the instructions. Some files as example files are not copied to the PC.

17.2 License conditions

- We grant the orderer a non-exclusive and non-transferrable right to use the HBM software on a single computer and at only one place.
- The licence holder is not permitted
 - To pass on or otherwise make the software or associated material accessible to third parties without prior written agreement from HBM.
 - To modify the software without prior written consent from HBM.
 - To create works derived from software or to duplicate the written material.
 - To translate or modify it or to create works derived from the written material.
- The right of use is dependent on the orderers observance of these general conditions of supply: „HBM’s general conditions and terms of sale for software apply“.

17.3 Data backup

The setting of **TRADE** can be backed up on floppy disk or network after the calibration. The status of the calibration can thus be restored on a PC replacement. However, should you have made legal-for-trade changes to the system in the meantime, the original status can no longer be created. For data backup proceed as follows:

- Call up Option -> Parameter -> Service or Operator
- Click with the right mouse button on the context menu Figure 29, Item (2)
- Select "Backup"
- Enter the target directory
- The files are filed in the target directory

17.4 Restoration of data after PC replacement

TRADE offers the possibility of restoring the stored data, e.g. after the PC replacement of a defective PC if these have been backed up according to Section 17.3. Nevertheless changes which have been made in the meantime cannot be undone again by this. For restoring the data please proceed as follows:

- Select Option -> Parameter -> Service or Operator
- Click with the right mouse button on the context menu Figure 29, Item (2)
- Select "Restore"
- Enter the source directory
- The files are copied
- You must then start **TRADE** anew

Observe that restoration of data overwrite previous data !

18 Multiple Sessions

It is possible to start **HBM TRADE** several times. To differentiate between the relevant *sessions*, it is possible to transfer the following parameters to the **TRADE.EXE** program:

-? Shows an Info
-u=*Id* Sets session *Id* (see also *DDE Interface* chapter 19.1.1)
-w=*Wnr* Sets scale *Wnr*

Example for the use of 2 scales:

Session 1: **TRADE.EXE** -u=1 -w=1
Session 2: **TRADE.EXE** -u=2 -w=2

Example for the use of 2 scales when called via a Windows icon (input in properties ->target):

Session 1 "C:\Program Files\HBM\TRADE\trade.exe" -u=1 -w=1
Session 2 "C:\Program Files\HBM\TRADE\trade.exe" -u=2 -w=2

Notes: If the program is started multiply, the scale switch-over must basically be deactivated so that several sessions do not inadvertently scan the same scale (the same load cells/interfaces). If more than one sessions are active setup entry is not possible. Please shut down all sessions but the last one first.
If several sessions of TRADE are active, only those parameters of the scales can be changed, by means of which you carry out service access. However, this also allows maintenance work to be carried out on one set of scales, and the other scales to be operated normally. In this case, the general parameters are not to be altered. For this purpose only one session may be active.
From 5 sessions upwards, it is recommended to use Windows NT or Windows 2000.

19 Interface to not legal application

In order to implement further functions, the TRADE application subject to legal-for-trade calibration requirements can be connected to non-calibration applications such as e.g. logistics software, invoice printouts etc..

19.1 The Interfaces

19.1.1 Software Interface DDE

The module **HBM TRADE** works as a DDE-Server. DDE stands for Dynamic Data Exchange and enables the communication between Windows applications. DDE is especially meant for little data exchange. Other program modules (e.g. WinWord) can communicate as a so called DDE-Client with **HBM TRADE**.

19.1.2 Software Interface DLL

The module **HBM TRADE** can bind a DLL on demand. This contains an in-jump via all current weight-values, the statuses of the scales etc is handed over. Further more the answer-sentence of the last command to HBM TRADE is handed over. Since the not legal for trade DLL is called permanently, it is simply possible to process weight-data regularly, for example as remote display or control-unit.

19.1.3 DDE vs. DLL

With the DDE-Interface, the not legal for trade application orders information of HBM TRADE after demand or sends commands to it. On each command, HBM TRADE sends an answer (receipt). This process is inverted with the DLL. HBM TRADE hands over a record to the DLL regularly. As answer, the application can hand over a command to HBM TRADE (like DDE-Commands). The answer

hereupon is handed over in the next call of the DLL. One recognizes that DDE and DLL correspond to itself and that merely the initiator of the communication in the one case is the application (DDE) and in the other case HBM TRADE (DLL).

19.2 DDE interface

19.2.1 General

The communication to not legal-for-trade (or generally foreign) applications is through a DDE interface. Programs such as WinWord or Excel have simple BASIC commands for using the DDE interface. Please use the corresponding documentation.

Note: Observe that the legal-for-trade capability of HBM TRADE is guaranteed only if weights etc. are printed or stored only together with the signature generated by HBM TRADE.

The following parameters are required for the DDE interface:

Application/program: **TRADE.EXE**
 Server: **TRADE** (=name of the application)
TRADE_1 .. TRADE_n (for session 1..n)
 Topic: **IO** (Input/Output)
 Item for transmitting: **INPUT** (Application → **HBM TRADE**)
 Item for receiving: **OUTPUT** (**HBM TRADE** → Application)

19.2.2 Command Structure

A string of the following format is transmitted via DDE-POKE (transmitting or executing) command (not required parameters can be dispensed with):

<Command>;<Mode>;<Comment>;<Parameter 1>;...;<Parameter n>

- Mode: Reserved; currently not used and without significance.
- Comment: Free text which serves as user key for the calibration file.
- Parameter: Further data according to command. The parameter is used currently only for the manual tare.

19.2.3 Commands

@WU;;<Comm.>;<nr>	Switching over to scale <no.>
@GR;;<Comm.>	Fetch weight at rest
@GC;;<Comm.>	Fetch weight at rest and save in DSD file
@GI;23;<Comm.>	Fetch weight
@NU;23;<Comm.>	Zero scale
@TW;23;<Comm.>	Tare scale
@TD;23;<Comm.>	De-tare scale
@TH;23;<Comm.>;<Tare>	Set manual tare
@YC;23;<Comm.>;<Signature>	Save data record in DSD file
@YH;23;<Comm.>;	Request header and reduce display. (If the maintenance message is shown, no reduction is effected. The user must first close the maintenance message.)
@AD;;;<nr>	Information on the individual transducer of the current scales with a continuous number. See below for details.

Information on command **@AD**:

- ◆ The numbering starts to the left in the transducer table (see Figure 36 – Load cell setting).
- ◆ If the parameter no. is positive, then the measured values for all transducers are re-determined. In the event of a negative no. the values stored in previously are output (simultaneity of measured values).

- ◆ The command @AD behaves like a normal command, that is all response fields are filled in normally. The transducer measured values are returned in the type plate field, and comprise: IDN of the load cell + Chr\$(124) + AD value or digital value of the transducer +Chr\$(124) + real load on the transducer in weight units + Chr\$(124) + gross value relative to the original zero (Due to the different zero point values, the sum of the individual gross values can deviate from that shown in the display of the scales)

Example:

@TH;;Set tare;1.234

Response (DDE scan, request):

HBM TRADE returns a data record containing all relevant data:

“Field 1“, “Field 2“, ..., “Field n“

Each field is included in inverted commas. The separator is a comma (not semicolon!).

Exactly the data which are set in the ‘Command-Panel’ window, Chapter 6 are returned. You can have the head data (designations) of these fields transferred with the command @YH.

All commands except @GI lead to the restoration of the TRADE main window if this has been minimized to the task bar. Use the command @YH to minimize the main window again to the Windows task bar.

19.3 DLL interface

HBM TRADE calls up a DLL with the name *tradedsp.dll* in each weighing cycle. If the DLL is not available, the selection does not apply. Thus for instance second displays or external processes can be controlled.

The following parameters are required for the DLL interface:

Name of the DLL:	TRADESP.DLL
Location:	Directory such as TRADE.EXE or Windows directory
Entry:	__declspec(dllexport) int execute(void *vp);

A structure which contains essentially the above described fields (DDE) is transferred through the parameter *vp*:

- Command (-1=Init of the DLL/0=display of the data)
- Mode (display mode – scale/log)
- Scale number
- Result of the current weighing:
 - DDE response record as single variable
 - Stable, error, under minimum load, zero, range as flags
 - Weights as numerical value
 - Message of the status line
 - Flag whether data record was renewed
- Result corresponding to last DDE response
- Next command to **HBM TRADE**

Return values:

- Next command to **HBM TRADE** (in *vp structure* – see above).
- 0, if command was processed or 1 if a new command to **HBM TRADE** is present.

20 Change of Load Cells

To replace defective load cells please proceed according to the following scheme:

- Fit new load cell, write down old and new serial numbers
- Call up **TRADE**, a checksum error is displayed
- Option -> Parameter -> Service
- Single Scale -> Parameter/Load Cell -> AD, Figure 38 appears
- Switch off poll
- (1) Overwrite old serial number with new serial number, do not change the address
- (2) Activate Set - not Scan !
- Acknowledge automatic address allocation with NO. Thus the new load cell is set to the old address.
- (4) If load cells of further scales are displayed, these must be switched off again.
- Switch poll back on, check that all associated load cells deliver a signal.
- (5) End and take over data. Notify this change to the responsible authorities !

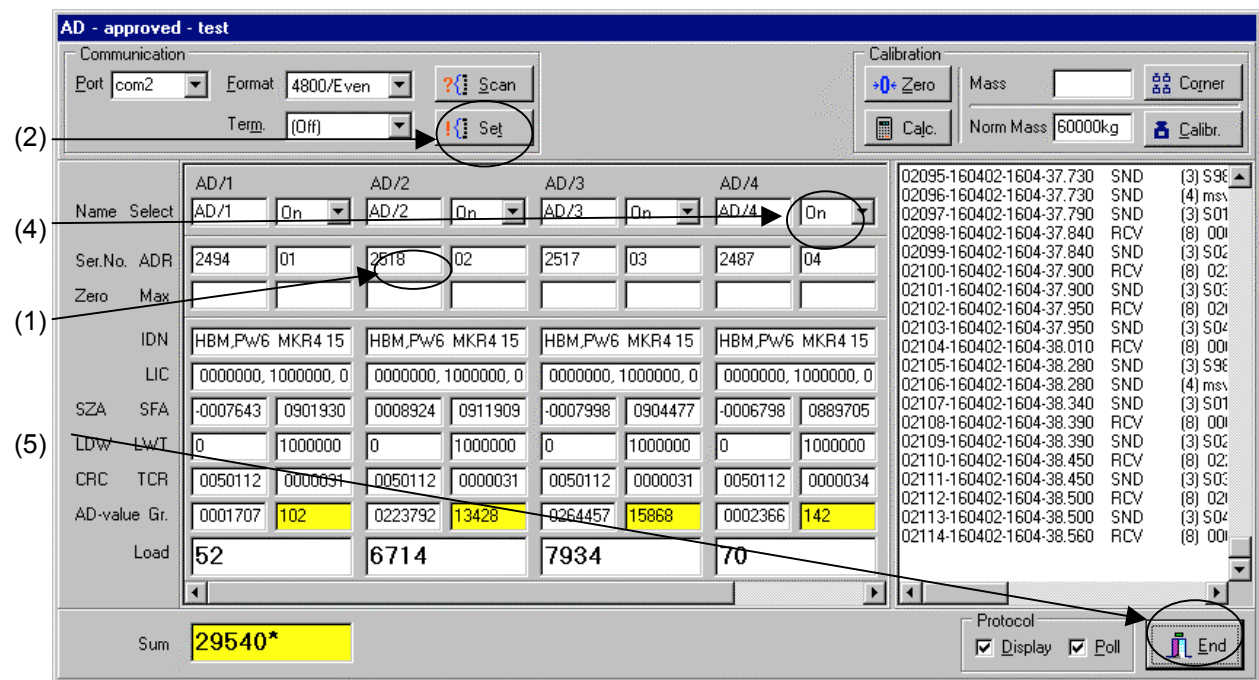

Figure 38 – Replacement of load cells

Observe that changes in the legal-for-trade area change the checksums and thus a possibly existing calibration is annulled.

21 Multiple Scale Systems

You can operate several scales with **TRADE**. The following alternatives exist:

21.1 Several scales with one session at a COM port

In this case you must always be sure which load cells belong to which scale. If you change these over, you can under certain circumstances destroy involuntarily the calibration of another scale. Scan should be used carefully in particular. It is better to initialize all scales with Set and only to state the load cells belonging to the corresponding scale. If a further scale is registered, then naturally other addresses must be allocated for the load cells. Automatic address allocation is not advisable.

- Your system can consist of a maximum of 16 load cells
- Only one scale can be displayed always at one time

21.2 Several scales with one session at different COM ports

This configuration is uncritical. It is impossible to confuse between load cells since these are separated on the hardware side.

- Your system can consist of a maximum of 8 scales (at COM1 to COM8) with 16 load cells each
- Only one scale can be displayed always at one time

21.3 Several scales with several sessions at different COM ports

This configuration is also uncritical. Confusion between load cells is also impossible since these are separated on the hardware side.

- Your system can consist of a maximum of 8 scales (8 sessions at 8 ports COM1 to COM8) with 16 load cells each
- All scales can be displayed simultaneously

Note: If the program is started several times, the scale switch-over must be deactivated basically so that several sessions do not scan the same scale (the same load cells/interfaces) inadvertently.

TRADE supports PC-ports COM1 to COM8. Others are not supported.

If several sessions of **TRADE** are active, only those parameters of the scales can be changed, by means of which you carry out service access. However, this also allows maintenance work to be carried out on one set of scales, and the other scales to be operated normally. In this case, the general parameters are not to be altered. For this purpose only one session may be active.

22 Parameters/Files

22.1 General parameters (TRADE_G.WPD)

Group	Area	Parameters	Values
General	Company	CNo. – Customer number	Text
		Check No. – Software licence	Text
		Name 1	Text
		Name 2	Text
	DSD file	Directory	Windows path
		Signature coded	On/Off
		Storage in months	3 .. 36
	Display	Scan frequency	On / 1/s .. 20/s
		Timeout	Off / 0.5s .. 20s
		Stable with unit	On/Off
		Log/line number	100 .. 1000
		Language	Available *.XLG files
		Printing mode	Unformatted Fitting Proportional
	Passwords	User	Text
		Service	Text

Note: Passwords are stored coded.

22.2 Communication parameters (TRADE_K.WPD)

Group	Area	Parameters	Values
Commun.	General	Port	Windows interface
		Format	Baud rate/Parity
		Bus termination	Off / Adr. 0 .. 31
	Per load cell	Address	0 .. 31

22.3 Legal-for-trade parameters – Check numbers

Group	Area	Parameters	Values
Checking	Parameter	Check number/status	
	Program	Check number/status	
		Version	
	Changes	Audit trail counter of the system (sum of the scales+program)/status	
	Remarks	Remarks of the legal-for-trade official	Text
	Per scale	Audit trail counter of the sale (sum of the single TCR)/status	
Check number/status			

Note: Check numbers etc. are stored coded.

22.4 Not legal-for-trade parameters/per scale (TRADE_W.WPD)

Group	Area	Parameters	Values
Scale	Designation	Name	Text
		Selection	On/Off
		System	Text
		Unit	Text
	Scan	Scan frequency	Off / 1/s .. 20/s
		Timeout	Off / 0.5s .. 10s
	Functions	Scale switch-over	On/Off
		Tare functions	On/Off
		Zero setting	On/Off
		High resolution	On/Off
		Weighing	On/Off
		Log	On/Off
		Parameters/fonts	On/Off
	Load cells	Weighing window	On/Off
		ASF – Filter stage	Off / 1 .. 8
		FMD - Filter fast	On/Off
ICR – Sampling rate		1/s .. 100/s	
	Test clock	Off / 1s .. 20s	

22.5 Legal-for-trade parameters/per scale (TRADE_E.WPD)

Group	Area	Parameters	Values
Scale	Name plate	Labelling	Text
		Min load/unit	Value
		Unit	Text
		Additional texts for unit	Text
		Character set	Windows character set
	Weighing ranges	Scale type	1-3Range/2-3Interval
		Calibration value (per range)	Value 1-3
		MaxLoad/unit (per range)	Value 1-3
	Application	Type	Industrial Trade OIML/NTEP Simulation
		Nominal load/unit	Value
	Location	Location	Text
		g constant	Value
	Zero	Range tracking	Off / 0.1d .. 20d
		Time tracking	Off / 0.2s .. 2s
		Zero setting	Off -1%/+3% +/-2% +/-20% +/-100%
		Automatic power on	Off +/-10% .. +/-100%
	Stable	Change	Off / 0.1d .. 20d
		Time	Off / 0.2s .. 2s
	Per load cell	Name	Text
		Selection	On/Off
		IDN – Serial number	Text
		SZA/SFA – Factory characteristic	Value
		LDW/LWT – User characteristic	Value
		LIC – Linearization	Values
		CRC – Check number	Value (CRC through <i>name plate..stable</i>)
		TCR – Audit trail counter	Value (Autoincrement, is increased on writing one of

Group	Area	Parameters	Values
			the above parameters)
		Zero/Max – User characteristic TRADE	Value

22.6 Legal-for-trade parameters/per load cell (storage in AD/10x)

Group	Area	Parameters	Values
Load cell	Calibration	IDN, SZA/SFA, LDW/LWT, LIC	Factory setting
		SZA/SFA – Factory characteristic	Factory setting
		LIC – Linearization	Factory setting
		LDW/LWT – User characteristic	0/1000000
		NOV – Scaling	1000000
		ZSE/ZTR - Zero setting/tracking	0/0
		CRC – Legal-for-trade parameters outside the load cell (see above)	Value
		TCR – Audit trail counter	Autoincrement on changing a calibration parameter
	Other	ADR - Address	0 .. 31
		BDR – Baud rate/Parity	1200 .. 19200 Bd/Odd/Even
		STR – Termination	On/Off
		COF/TEX – Output format	3/172 (fixed)
		ASF/FMD - Filter	0..8/0..1
		ICR – Sampling rate	0..7
		TAV/TAS - Tare	0/1 (fixed)

23 Trade marks

Microsoft, Word and Excel are registered trade marks of the Microsoft Corp.
 Borland, C++Builder and Delphi are registered trade marks of the Borland Corp.

24 Index

I

10-times resolution 7

A

Adjust scale 49

Adjustment by calculation 48

Adjustment without weights 48

AED9101x 43, 47

Audit trail counter 16, 44

B

Background colour 14

Backup 19, 36

Baud rate 46

BLOCKED 37

Bus address 46

Bus termination 46

C

Calibration data 19, 38

Command 12, 52

Context menu 19, 36

Converter 27

Corner adjustment 45, 49

D

Data backup 50

Data-Storage-Device 10

DDE interface 52

Display/print settings 18, 36

DLL interface 53

DSD 10

F

Filter 21, 40

First step 28

Flash Memory 10

Font 14, 41

G

g-factor 43

I

Interface 46

L

Language 20, 38

LC-Code Error 34

M

M green 8

M red 9

Maintenance 37

maintenance symbol 9

Maximum load 42

N

Name plate 41

New scale 39

Nominal load cell load 43

NTEP 42

O

OIML 42

Overload 44

P

Parallel connection of the load cells 24

Passwords 20, 38

PC replacement 17, 19, 50

PC requirements 50

Poll 48

Power up zero 43

Printer 20, 38

Q

Quick instruction 28

R

Range indication 9

Replacement of load cells 54

Restore after PC replacement 19

Restore data after PC replacement 19, 36

Restoring after PC replacement 17, 50

S

Scale history 18, 36

Sealing 24

Second display 53

Serial numbers of the load cells 46

Serial numbers unknown 47

Sessions 51, 55

SETUP.EXE 50

Several scales 55

Signature 13

Simulation 14

Stable criterion 43

Stable indication 9

T

Test 14

Test identifier 9

Toolbar 7

TRADE multiple start 51

W

Weighing list 8, 20, 38

Z

Zero indication 9

Zero setting 43

Zero tracking 43